



# DRIVING CIRCUIT DESIGN GUIDE

## FOR BACKLIGHT AND DC-DC CONVERTER

Rev.1.2  
2024-03-08

This document is applied for the Riverdi HB, IPS, 7.0" RGB series:

PRODUCT NAME	DESCRIPTION
RVT70HSTNWN00	HB, IPS, 7.0", 1024x600, 1000cd/m <sup>2</sup> , RGB, No touch panel,
RVT70HSTFWN00	HB, IPS, 7.0", 1024x600, 1000cd/m <sup>2</sup> , RGB, No touch panel, Metal frame
RVT70HSTNWC00-B	HB, IPS, 7.0", 1024x600, 850cd/m <sup>2</sup> , RGB, uxTouch, Optical bonding
RVT70HSTNWC00	HB, IPS, 7.0", 1024x600, 800cd/m <sup>2</sup> , RGB, uxTouch, Air bonding
RVT70HSTNWCA0	HB, IPS, 7.0", 1024x600, 800cd/m <sup>2</sup> , RGB, aTouch, Air bonding
RVT70HSTFWCA0	HB, IPS, 7.0", 1024x600, 800cd/m <sup>2</sup> , RGB, aTouch, Air bonding, Metal frame



1. REVISION RECORD

REV NO.	REV DATE	CONTENTS	REMARKS
1.0	2022-09-05	Initial Release	
1.1	2024-02-05	Change R23 value to 30.9k and change R21 value to 22k to have VGL voltage -6V. Correct MIN and MAX values of VGL	
1.2	2024-03-08	Added information about input voltage for BLVCC.	



**2. CONTENTS**

- 1. REVISION RECORD..... 2
- 2. CONTENTS..... 3
- 3. BACKLIGHT DRIVING CIRCUIT ..... 4
- 4. DRIVING CIRCUIT OF VGH/VGL/ AVDD/VCOM..... 6



### 3. BACKLIGHT DRIVING CIRCUIT

Internal backlight circuit of Riverdi HB, IPS 7.0" RGB Series is built with 9x3 (3LEDs in a row) LED matrix.

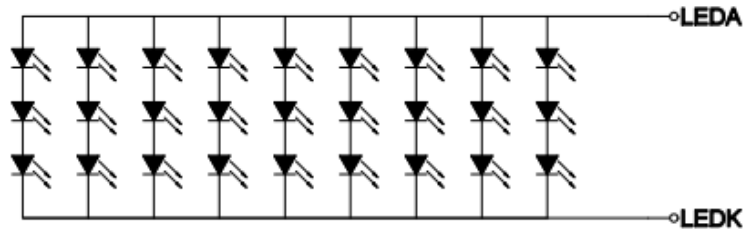

LED Diagram Circuit

**Backlight parameters of Riverdi 7.0" HB, IPS series:**

PARAMETER	SYMBOL	MIN	TYP	MAX	UNIT	NOTE
Backlight Driving Voltage	$V_F$	9.0	9.6	10.2	V	
Backlight Driving Current	$I_F$	-	270	-	mA	
Backlight Power Consumption	$W_{BL}$	-	2592	-	mW	
LED Lifetime	-	-	50,000	-	hours	Note 1

To get the full brightness, the driving current ( $I_F$ ) needs to reach 270 mA.

The recommended LED driver is TPS61169 or DIO566,

**The input voltage for BLVCC is in range 2.7 to 5.5V.**

For example, the feedback voltage of TPS61169:  $V_{FB} (max)=204mV$

In our design, R34, R35 connected in parallel as a feedback resistor ( $R_{FB}$ ) is set to 0.75R to achieve the full brightness.

$$I_F (max)=V_{FB} (max)/ R_{FB}$$

$$I_F (max)=204mV/0.75R= 272 mA.$$

Both TPS61169 and DIO5661 have PWM dimming control input to drive the LED current. TPS61169 and DIO5661 have built-in low-pass filter which changes internal feedback voltage. By that, inverter is not switched on-off with PMW signal but change LEDs current effectively in continuous way which cause low EMI emissions.

Please note that all Riverdi displays are designed to have low emission, that's why many LC components like beads and capacitors are on the schematic. They are not necessary but strongly recommended.

Recommended PMW frequency is 5kHz – 100kHz for TPS61169 or 200Hz - 200kHz for DIO5661.

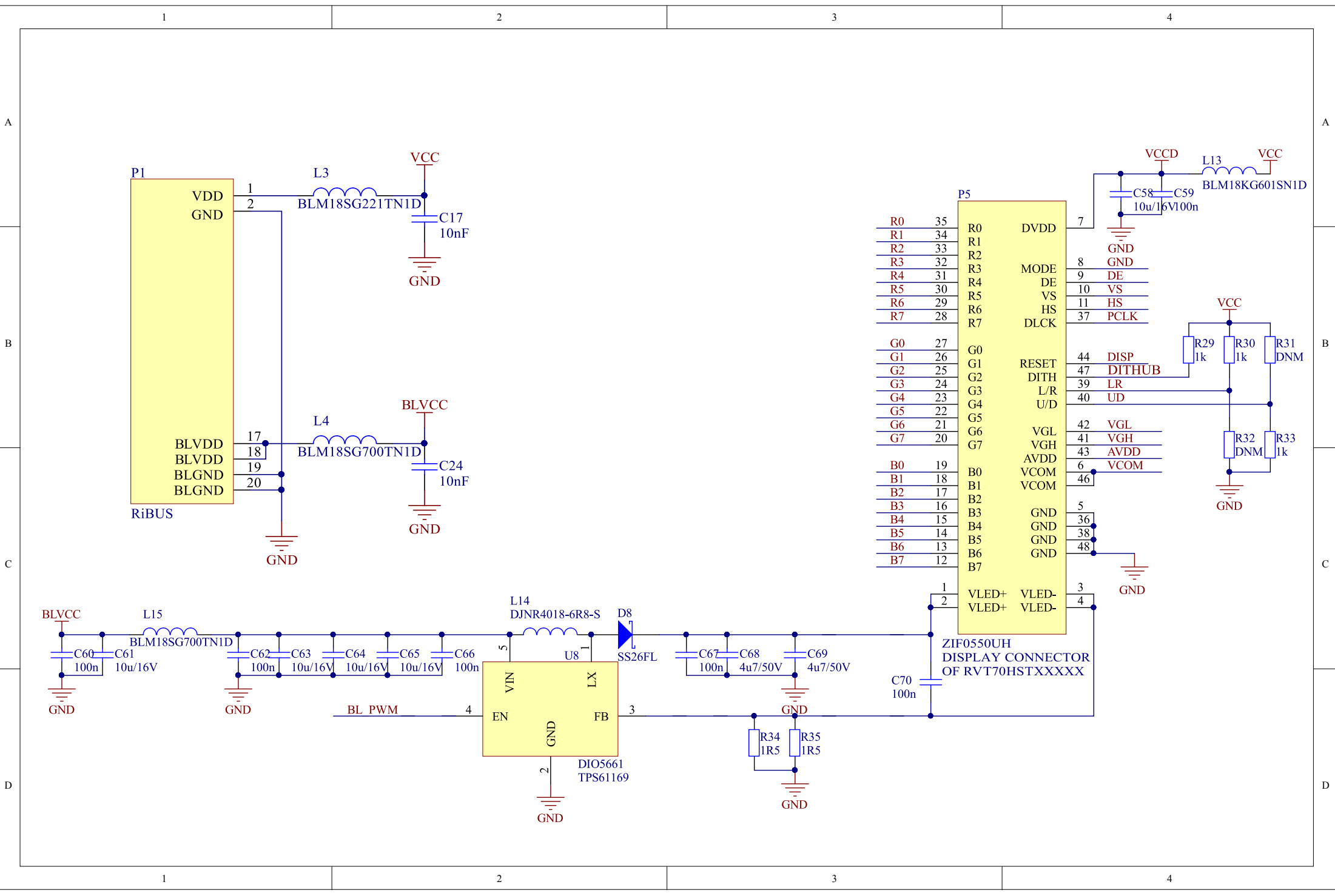



## 4. DRIVING CIRCUIT OF VGH/VGL/ AVDD/VCOM

Riverdi HB, IPS, 7.0" RGB series TFT require VGH, VGL, AVDD and VCOM voltages to drive the TFT glass driver properly.

Below tables are the VGH, VGL, VCOM, and AVDD specifications for Riverdi HB, IPS, 7.0" RGB series.

### Absolute maximum ratings:

PARAMETER	SYMBOL	MIN	MAX	UNIT
Power for Circuit Driving	VDD	-0.3	3.96	V
	AVDD	-0.5	14.85	
	VGH	-0.3	40	
	VGL	-20.0	0.3	

### Electrical specifications:

PARAMETER	SYMBOL	MIN	TYP	MAX	UNIT	NOTE
Supply Voltage for Module	VGH	17	18	19	V	
	VGL	-5.4	-6.0	-6.6		
	AVDD	9.4	9.6	9.8		
	VCOM	3.6	3.8	4.0		
Current of Power Supply	IAVDD	-	35	45	mA	AVDD = 9.6V
	IGH	-	0.5	1	uA	VGH = 18V
	IGL	-	0.5	1	mA	VGL = -6V

The schematic of VGH, VGL, AVDD and VCOM circuit with AP3012KTR-E1 DC-DC converter.

Hi, I am here to help you!  
If you have any additional questions, please contact our support via email: [contact@riverdi.com](mailto:contact@riverdi.com)



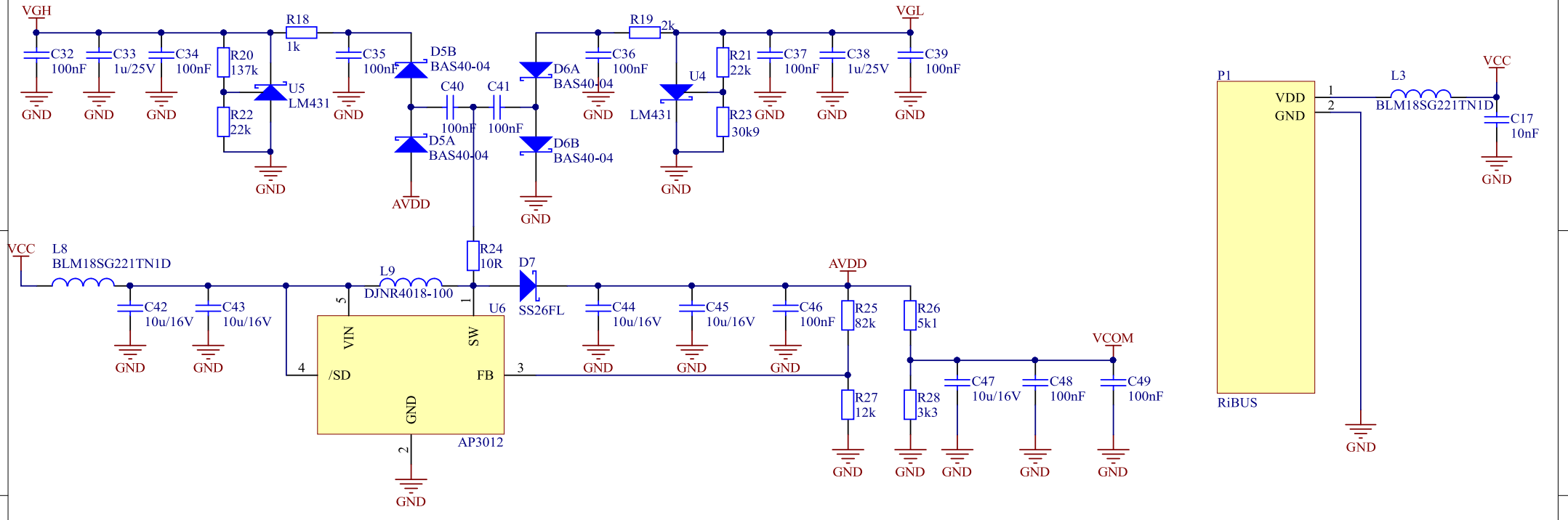

A

B

C

D

1

2

3

4

1

2

3

4

A

B

C

D