



TFT MODULE SPECIFICATION

RVT35HITNWC00-B

HB, IPS 3.5" LCD TFT display datasheet
Rev. 1.0
2024-11-19

Riverdi Sp. z o.o.

Nowy Swiat 36
80-299 Gdansk, Poland
VAT ID: PL5842767153
Registration number (KRS): 0000923967

+48 587 703 116

Office hours: 9:00 to 17:30 CET (Mon-Fri)

contact@riverdi.com

riverdi.com

ITEM	CONTENTS	UNIT
LCD Type	TFT/Transmissive/Normally Black/IPS	/
Size	3.5	Inch
Viewing Direction	Free	/
Outside Dimensions (W x H x D)	59.56 x 93.34 x 5.66	mm
Active Area (W x H)	48.96 x 73.44	mm
Pixel Pitch (W x H)	0.153 x 0.153	mm
Resolution	320 (RGB) x 480	/
Brightness	1200	cd/m ²
LCD Interface Type	RGB/SPI	/
Color Depth	262K	/
Pixel Arrangement	RGB Vertical Stripe	/
With/Without Touch	With Projected Capacitive Touch Panel	/
CTP Driver	ILI2130	/
Touch Interface Type	I2C	/
Bonding Technology	Optical Bonding	/
Weight	55	g

Note 1. RoHS3 compliant

Note 2. LCM weight tolerance: $\pm 5\%$.

1. REVISION RECORD

REV NO.	REV DATE	CONTENTS	REMARKS
1.0	2024-11-19	Initial Release	

2. CONTENTS

1.	REVISION RECORD	3
2.	CONTENTS	4
3.	MODULE CLASSIFICATION INFORMATION	5
4.	MODULE DRAWING	6
5.	ABSOLUTE MAXIMUM RATINGS	7
6.	ELECTRICAL CHARACTERISTICS	7
7.	BACKLIGHT ELECTRICAL CHARACTERISTICS	8
8.	ELECTRO-OPTICAL CHARACTERISTICS	9
9.	INTERFACES DESCRIPTION	12
9.1	TFT assignment	12
10.	TIMING CHARACTERISTICS	14
11.	INSPECTION	16
11.1	Inspection condition	17
11.2	Inspection standard	18
12.	RELIABILITY TEST	20
13.	LEGAL INFORMATION	21
14.	CONTACT	22

3. MODULE CLASSIFICATION INFORMATION

RV	T	35	H	I	T	N	W	C	00	B
1.	2.	3.	4.	5.	6.	7.	8.	9.	10.	11.

NO.	PARAMETER	SYMBOL
1.	BRAND	RV - Riverdi
2.	PRODUCT TYPE	T - TFT Standard
3.	DISPLAY SIZE	35 - 3.5"
4.	MODEL SERIAL NO.	H - High Brightness, IPS
5.	RESOLUTION	I - 320 x 480 px
6.	INTERFACE	T - RGB/SPI
7.	FRAME	N - Without Mounting Metal Frame
8.	BACKLIGHT TYPE	W - LED White
9.	TOUCH PANEL	N - Without Touch Panel
10.	VERSION	00 - (00-99)
11.	BONDING TECHNOLOGY	B - Optical bonding

Revision:	Changes:	Date:
1.0	Initial Case	2024.11.19

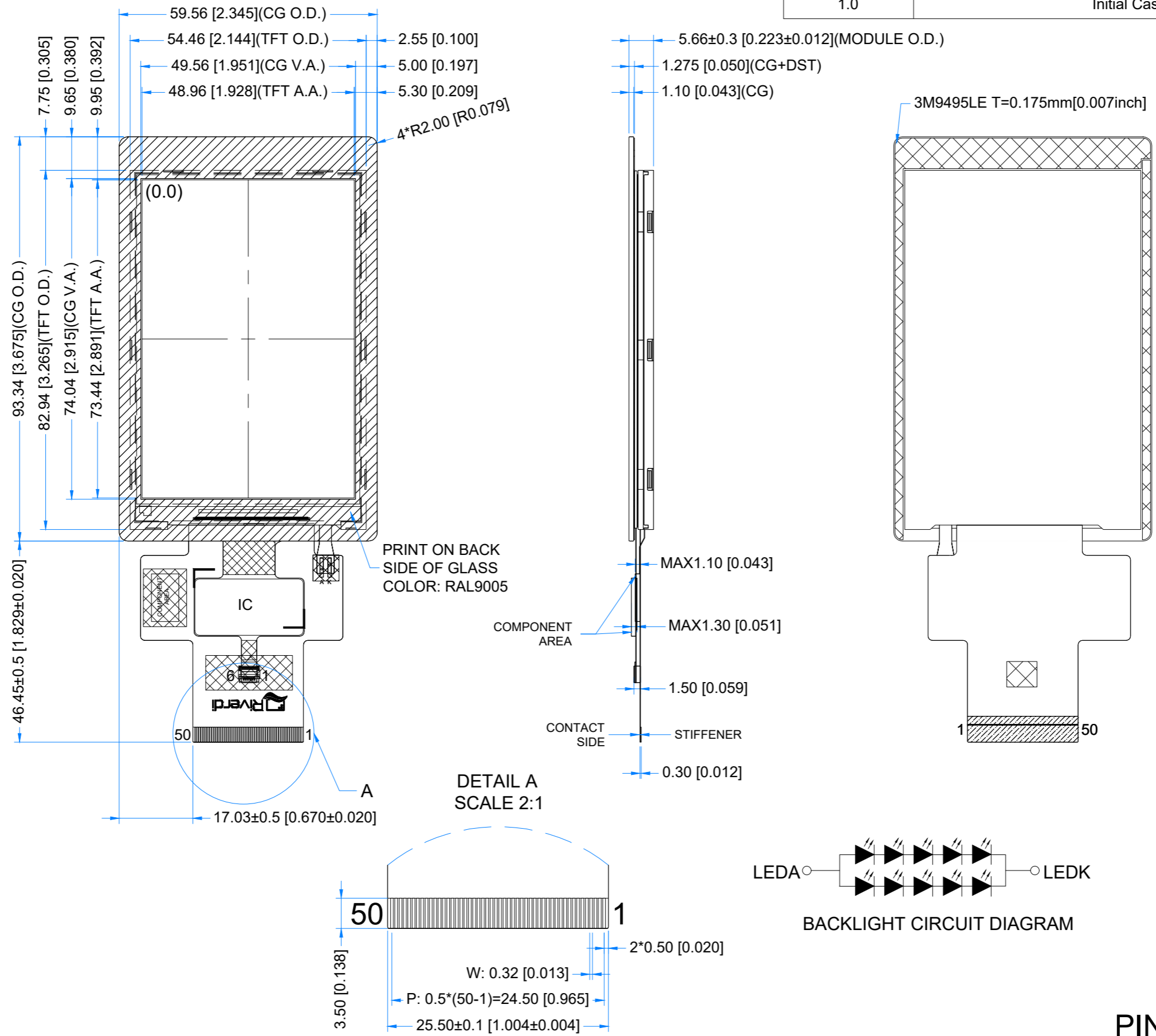

PINOUT ON THE 2ND PAGE

TFT NOTES:

1. DISPLAY TYPE: TFT, TRANSMISSIVE, RNOMALLY BLACK
2. RESOLUTION: 320*480
3. VIEWING ANGLE: FREE
4. DRIVER IC: ILI9488
5. SURFACE LUMINANCE: 1200cd/m²
6. BACKLIGHT: 10LEDS, V_f=14-16v, I_f=100mA

TP NOTES:

1. TP STRUCTURE: G+G
2. DRIVER IC: ILI2130
3. OPERATING VOLTAGE: 2.8V
4. SURFACE HARDNESS: ≥6H
5. TRANSMITTANCE: ≥80%

GENERAL NOTES:

1. OPERATING TEMPERATURE: -20°C ~ 70°C
2. STORAGE TEMPERATURE: -30°C ~ 80°C
3. WITHOUT INDIVIDUAL TOLERANCE: ±0.2mm
4. RoHS COMPLIANT

PN: RVT35HITNWC00-B

SN:

DRAWN: M.Natywa

CHECKED: M.Wierzbowski

APPR:

2024.11.19	1:1.00	
2024.11.19	[mm]	
ISO A3	P. 1 of 1	

5. ABSOLUTE MAXIMUM RATINGS

PARAMETER	SYMBOL	MIN	MAX	UNIT
Supply Voltage for Module	V_{CI}	-0.3	3.3	V
Interface Supply Voltage	IOVCC	-0.3	3.3	V
Input Voltage	V_{IN}	-0.3	VDD+0.3	V

Note. The above are maximum values. If exceeded, they may cause permanent damage to the unit.

6. ELECTRICAL CHARACTERISTICS

PARAMETER	SYMBOL	MIN	TYP	MAX	UNIT
Supply voltage	V_{CI}	2.5	2.8	3.3	V
Interface Supply voltage	IOVCC	1.7	1.8	3.3	V
Input High Voltage for LCD	V_{IH}	$0.7 \cdot IOVCC$	-		V
Input Low Voltage for LCD	V_{IL}	VSS	-	$0.3 \cdot IOVCC$	V
Output High Voltage for LCD	V_{OH}	$0.8 \cdot IOVCC$	-		V
Output Low Voltage for LCD	V_{OL}	VSS	-	$0.3 \cdot IOVCC$	V

7. BACKLIGHT ELECTRICAL CHARACTERISTICS

PARAMETER	SYMBOL	MIN	TYP	MAX	UNIT	NOTE
Backlight Driving Voltage	V_F	13.5	15.0	17.0	V	Notes 1, 2
Backlight Driving Current	I_F	-	100	-	mA	
Backlight Power Consumption	W_{BL}	-	1.5	-	W	
Backlight Lifetime	-	-	30,000	-	hours	Note 3

Note 1. Unless specified, the ambient temperature $T_a = 25^\circ\text{C}$

Note 2. The recommended operating conditions refer to a range in which operation of this product is guaranteed. The operation cannot be guaranteed if the absolute maximum values exceed.

Note 3. If LED is driven by high current, high ambient temperature and humidity condition, the lifetime of LED will be reduced. Operating life means brightness goes down to 50% initial brightness. Typical operating lifetime is estimated data.

8. ELECTRO-OPTICAL CHARACTERISTICS

ITEM	SYMBOL	CONDITION	MIN	TYP	MAX	UNIT	RMK	NOTE
Response Time	Tr+Tf	$\theta=0^\circ$ $\phi=0^\circ$ Ta=25 °C	-	30	-	ms	FIG 1.	4, 7
Contrast Ratio	Cr		-	700	-	---	FIG 2.	1, 7
Surface Luminance	Lv		-	1200	-	cd/m ²		2, 7
Viewing Angle Range	θ	$\phi = 90^\circ$ $\phi = 270^\circ$ $\phi = 0^\circ$ $\phi = 180^\circ$	-	80	-	deg	FIG 3.	6
			-	80	-	deg		
			-	80	-	deg		
			-	80	-	deg		
CIE (x, y) Chromaticity	Rx	$\theta=0^\circ$ $\phi=0^\circ$ Ta=25 °C	-	0.660	-	-	FIG 2.	5,7
	Ry		-	0.325	-	-		
	Gx		-	0.277	-	-		
	Gy		-	0.568	-	-		
	Bx		-	0.145	-	-		
	By		-	0.072	-	-		
	Wx		-	0.276	-	-		
	Wy		-	0.325	-	-		

Note 1. Contrast Ratio (CR) is defined mathematically as below, for more information see Figure 2.

$$\text{Contrast Ratio} = \frac{\text{Average Surface Luminance with all white pixels (P1, P2, P3, P4, P5)}}{\text{Average Surface Luminance with all black pixels (P1, P2, P3, P4, P5)}}$$

Note 2. Surface luminance is the LCD surface from the surface with all pixels displaying white. For more information see Figure 2.

$$L_v = \text{Average Surface Luminance with all white pixels (P1, P2, P3, P4, P5)}$$

Note 3. The uniformity in surface luminance δ WHITE is determined by measuring luminance at each test position 1 through 5, and then dividing the minimum luminance of 5 points luminance by maximum luminance of 5 points luminance. For more information see Figure 2.

$$\delta \text{ WHITE} = \frac{\text{Minimum Surface Luminance with all white pixels (P1, P2, P3, P4, P5)}}{\text{Maximum Surface Luminance with all white pixels (P1, P2, P3, P4, P5)}}$$

Note 4. Response time is the time required for the display to transition from white to black (Rise Time, T_r) and from black to white (Decay Time, T_f). For additional information see Figure 1. The test equipment is BM-7A.

Note 5. CIE (x, y) chromaticity, the x, y value is determined by measuring luminance at each test position 1 through 5, and then make average value.

Note 6. For TFT module, viewing angle is the angle at which the contrast ratio is greater 10. The angles are determined for the horizontal or x axis and the vertical or y axis with respect to the z axis which is normal to LCD surface. For more information see Figure 3.

Note 7. Viewing angle is measured at the center point of the LCD by CONOSCOPE (ergo-80). For response time testing, the testing data is based on BM-7A. Instruments for Contrast Ratio, Surface Luminance, Luminance Uniformity, Chromaticity the test data is based on SR-3A.

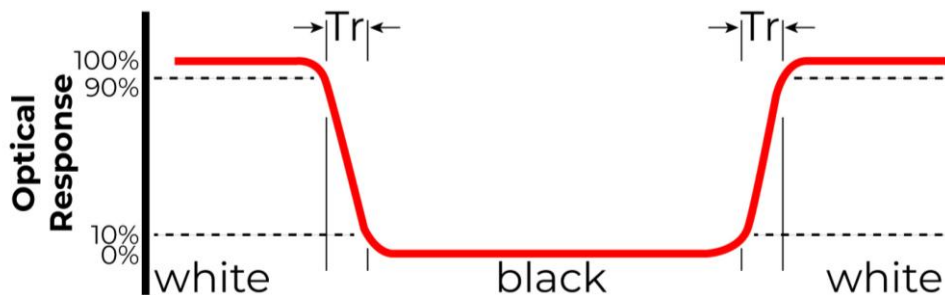

Figure 1. The definition of response time

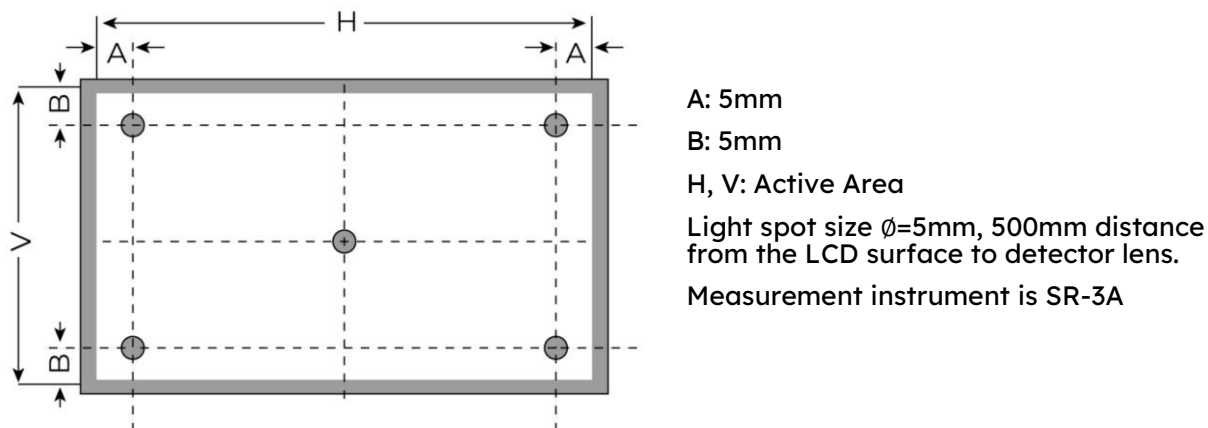

Figure 2. Measuring method for Contrast ratio, surface luminance, Luminance uniformity, CIE (x, y) chromaticity

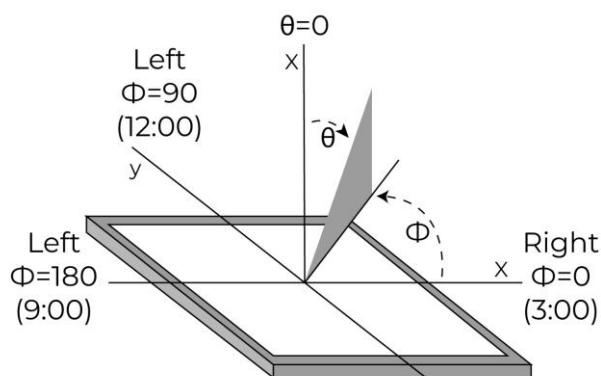

Figure 3. The definition of viewing angle

9. INTERFACES DESCRIPTION

9.1 TFT assignment

PIN	SYMBOL	I/O	DESCRIPTION	NOTE
1	GND	P	Ground	
2	V _{CI}	P	System Voltage	
3	I _{M0}	-	The interface mode select (Note 2)	
4	I _{M1}	-	The interface mode select (Note 2)	
5	I _{M2}	-	The interface mode select (Note 2)	
6	RESET	I	Reset signal	
7	VS _{SYNC}	I	Vertical synchronizing signal	
8	HS _{SYNC}	I	Horizontal synchronizing signal	
9	PCLK	I	Dot clock signal	
10	DE	I	Data enable signal	
11-34	DB23~DB0	I	Data bus	
35	TE	I	Tear effect signal	
36	SDO	O	Serial data output	
37	SDA	I	Serial data input signal	
38	RD	I	Read signal	
39	WR/SCL	I	DBI Type B: WRX pin, serves as write signal DBI Type C: SCL pin, as serial Clock when operates in the serial interface	
40	DCX	I	Data/Command Selection pin; Low: Command High: Parameter	
41	CS	I	CS signal	
42	GND	P	Ground	

43	TP_RESET	I	TP Reset signal	
44	TP_INT	O	IIC Interrupt signal	
45	TP_SDA	O	IIC Data	
46	TP_SCL	I	IIC Clock Signal	
47	TP_VDD	P	CTP System Voltage	
48	GND	P	Ground	
49	LEDA	P	LED+	
50	LEDK	P	LED-	

Note 1. I: Input, O: Output, P: Power

Note 2. Interface mode select

IM2	IM1	IM0	INTERFACE
0	0	0	MCU18
0	0	1	MCU9
0	1	0	MCU16
0	1	1	MCU8
1	0	1	3-line SPI
1	1	1	4-line SPI

10. TIMING CHARACTERISTICS

PARAMETER	SYMBOL	MIN	TYP	MAX	UNIT
Horizontal synchronization	H_Low	3			DOTCLK
Horizontal back porch	HBP	3			DOTLCK
Horizontal address	HACT	-	320		DOTCLK
Horizontal front porch	HFP	3			DOTCLK
Horizontal frequency		-		33	Hz
Vertical synchronization	V_Low	1			Line
Vertical back porch	VBP	2			Line
Vertical address	VACT	-	480		Line
Vertical front porch	VFP	2			Line
Vertical frequency		60		70	Hz
DOTCLK cycle		100		50	ns
DOTCLK frequency		10		20	MHz

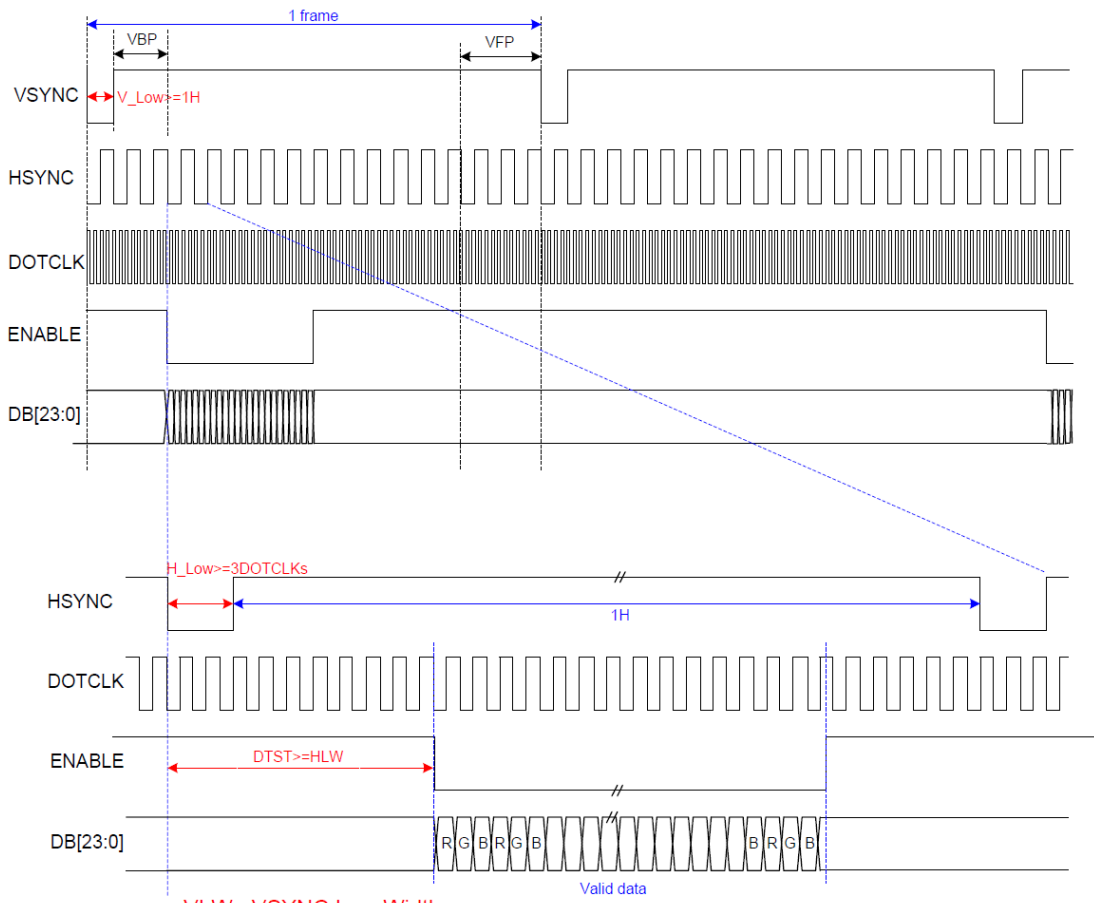

VLW : VSYNC Low Width
 HLW : HSYNC Low Width
 DTST : Data Transfer Startup Time

11. CAPACITIVE TOUCH SCREEN PANEL SPECIFICATIONS

11.1 Mechanical characteristics

DESCRIPTION	SPECIFICATION	REMARK
Touch Panel Size	3.5 inch	
Outline Dimension of CTP	93.34 mm x 59.56 mm	
Product Thickness	5.66 mm	
Glass Thickness	1.1mm	
CTP View Area	74.04 mm x 49.56 mm	
Surface Hardness	6H	

11.2 Electrical characteristics

DESCRIPTION	SPECIFICATION	REMARK
Linearity	+/-1.5mm	
Controller	ILI2130	
Resolution	320 x 480	
Device address 7-bit	0x41	

12. INSPECTION

Standard acceptance/rejection criteria for TFT module

12.1 Inspection condition

Ambient conditions:

- Temperature: $25 \pm 2^{\circ}\text{C}$
- Humidity: $(60 \pm 10) \%RH$
- Illumination: Single fluorescent lamp non-directive (300 to 700 lux)

Viewing distance: $35 \pm 5\text{cm}$ between inspector bare eye and LCD.

Viewing Angle: U/D: $45^{\circ}/45^{\circ}$, L/R: $45^{\circ}/45^{\circ}$

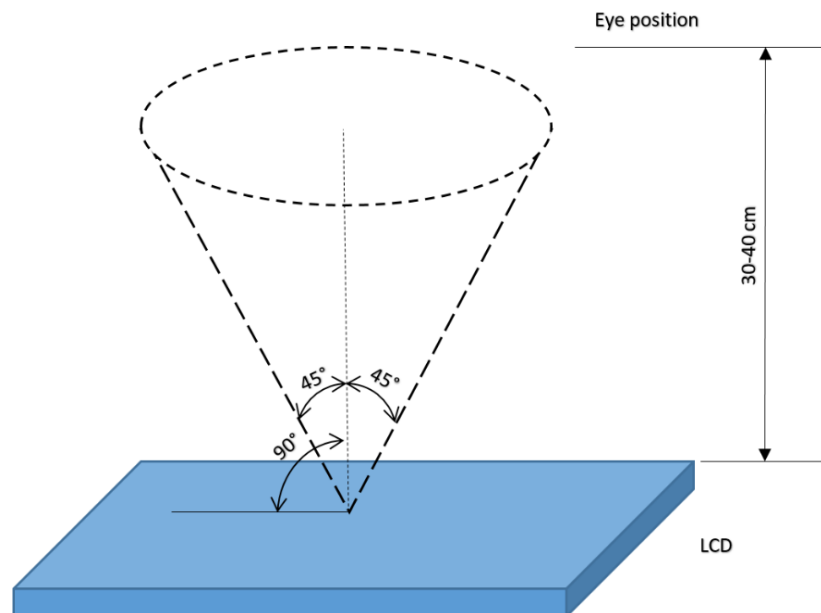

12.2 Inspection standard

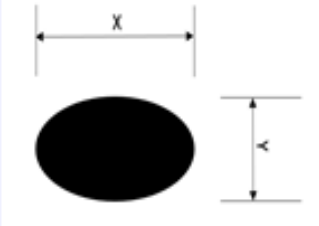
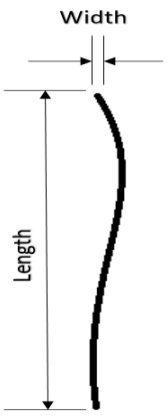
ITEM	CRITERION	Size = 3.5"			
Black spots, white spots, light leakage, Foreign Particle (round Type)	 <p>$D = (x+y)/2$</p> <p>Spots density: 10 mm</p>	Average Diameter			Qualified Qty
		$D \leq 0.2 \text{ mm}$			Ignored
		$0.2 \text{ mm} < D \leq 0.3 \text{ mm}$			$N \leq 5$
		$0.5 \text{ mm} < D$			Not allowed
LCD black spots, white spots, light leakage (line Type)	 <p>Spots density: 10 mm</p>	Size = 3.5"			
		Length	Width	Qualified Qty	
		-	$W \leq 0.05$	Ignored	
		$L \leq 3.0$	$0.05 < W \leq 0.1$	$N \leq 3$	
		$5.0 < L$	$0.1 < W$ $5.0 < L$	Not allowed	
Bright/Dark Dots	Size = 3.5"				
	Item		Qualified Qty		
	Bright dots		0		
	Dark dots		0		
	Cluster Bright Dots and Dark Dots		0		
	Total Bright and Dark Dots		0		

Clear spots	Size = 3.5"		
	Average Diameter		Qualified Qty
	D < 0.2 mm		Ignored
	0.2 mm < D < 0.3 mm		4
	0.3 mm < D < 0.5 mm		2
	0.5 mm < D		0
	Spots density: 10 mm		
Touch panel spots	Size = 3.5"		
	Average Diameter		Qualified Qty
	D < 0.3 mm		Ignored
	0.3 mm < D < 0.5 mm		$N \leq 5$
	0.5 mm < D		0
Touch panel white line scratch	Size ≥ 5.0 "		
	Length	Width	Qualified Qty
	-	$W \leq 0.07$	Ignored
	$L \leq 5.0$	$0.07 < W < 0.05$	$N \leq 5$
	-	$0.05 < W$	0

13. RELIABILITY TEST

NO.	TEST ITEM	TEST CONDITION	NOTE
1	High Temperature Storage	80°C/96 hours	Note 1
2	Low Temperature Storage	-30°C/96 hours	
3	High Temperature Operating	70°C/96 hours	
4	Low Temperature Operating	-20°C/96 hours	
5	High Temperature and High Humidity	Humidity 60°C, 90%RH, 96Hrs	
6	Electro static discharge	Contact = ±8kV, class B Air = ±15kV, class B	Note 2
7	Thermal Cycling Test (No operation)	-30°C for 30min, 80°C for 30 min. 20 cycles. Start with cold temperature, end with high temperature	
8	Vibration Test	Frequency: 10 ÷ 55 Hz. Stroke: 1.5 mm. Sweep: 10Hz ÷ 55Hz ÷ 10 Hz. 2 hours for each direction of X, Y, Z (Total 6 hours)	
9	Package Drop Test	Height: 60 cm 1 corner, 3 edges, 6 surfaces	

Note 1. Sample quantity for each test item is 5 ÷ 10 pcs.

Note 2. The device is kept at room temperature for 2 hours prior to starting the test

14. LEGAL INFORMATION

CE marking is usually obligatory only for a complete end product. Riverdi display modules are semi-finished goods which are used as inputs to become part of the finished products.

Therefore, Riverdi display modules are not CE marked.

This is not a standalone product. It was designed as an electronic component. It needs integration with a whole system to be fully functional.

Riverdi grants the guarantee for the proper operation of the goods for a period of 12 months from the date of possession of the goods. If in a consequence of this guaranteed execution the customer has received the defects-free item as replacement for the defective item, the effectiveness period of this guarantee shall start anew from the moment the customer receives the defects-free item.

Information about device is the property of Riverdi and may be the subject of patents pending or granted. It is not allowed to copy or disclosed this document without prior written permission.

Riverdi endeavors to ensure that all contained information in this document is correct but does not accept liability for any error or omission. Riverdi products are in developing process and published information may be not up to date. Riverdi reserves the right to update and makes changes to Specifications or written material without prior notice at any time. It is important to check the current position with Riverdi.

Images and graphics used in this document are only for illustrative the purpose. All images and graphics are possible to be displayed on the range products of Riverdi, however the quality may vary. Riverdi is no liable to the buyer or to any third party for any indirect, incidental, special, consequential, punitive, or exemplary damages (including without limitation lost profits, lost savings, or loss of business opportunity) relating to any product, service provided or to be provided by Riverdi, or the use or inability to use the same, even if Riverdi has been advised of the possibility of such damages.

Riverdi products are not fault tolerant nor designed, manufactured or intended for use or resale as on line control equipment in hazardous environments requiring fail-safe performance, such as in the operation of nuclear facilities, aircraft navigation or communication systems, air traffic control, direct life support machines or weapons systems in which the failure of the product could lead directly to death, personal injury or severe physical or environmental damage ('High-Risk Activities'). Riverdi and its suppliers specifically disclaim any expressed or implied warranty of fitness for High-Risk Activities. Using Riverdi products and devices in 'High-Risk Activities' and in any other application is entirely at the buyer's risk, and the buyer agrees to defend, indemnify and hold harmless Riverdi from all damages, claims or expenses resulting from such use. No licenses are conveyed, implicitly or otherwise, under any Riverdi intellectual property rights.

15. CONTACT

Your Success is Our Priority

Stuck on a technical challenge? Need expert guidance?
Our dedicated support team is just a message away.

Contact us at

contact@riverdi.com

We're here to ensure your project's success, every step of the way!