



TFT MODULE SPECIFICATION

RVT156HKLNWN00

HB, IPS LVDS 15.6" FULL HD LCD TFT display datasheet
Rev. 1.1
2026-02-06

Riverdi Sp. z o.o.

Nowy Swiat 36
80-299 Gdansk, Poland
VAT ID: PL5842767153
Registration number (KRS): 0000923967

+48 587 703 116

Office hours: 9:00 to 17:30 CET (Mon-Fri)

contact@riverdi.com

riverdi.com



ITEM	CONTENTS	UNIT
LCD Type	TFT/Transmissive/Normally Black/IPS	/
Size	15.6	Inch
Viewing Direction	All	/
Outside Dimensions (W x H x D)	360.00 x 212.30 x 6.40	mm
Active Area (W x H)	344.16 x 193.59	mm
Pixel Pitch (W x H)	0.1793 x 0.1793	mm
Resolution	1920 x 1080	/
Brightness	1000	cd/m ²
Color Depth	16.7 M	/
Pixel Arrangement	RGB Vertical Stripe	/
Interface	LVDS	/
With/Without Touch	Without Touch Panel	/
Weight	585	g

Note 1. RoHS3 compliant

Note 2. LCM weight tolerance: $\pm 5\%$.

1. REVISION RECORD

REV NO.	REV DATE	CONTENTS	REMARKS
1.0	2025-05-26	Initial release	
1.1	2026-02-06	Drawing LED diagram update	

2. CONTENTS

1.	REVISION RECORD	3
2.	CONTENTS	4
3.	MODULE CLASSIFICATION INFORMATION	5
4.	MODULE DRAWING	6
5.	ABSOLUTE MAXIMUM RATINGS	7
6.	ELECTRICAL CHARACTERISTICS	7
7.	BACKLIGHT ELECTRICAL CHARACTERISTICS	8
8.	ELECTRO-OPTICAL CHARACTERISTICS	9
9.	INTERFACES DESCRIPTION	12
9.1	TFT assingment	12
9.2	Backlight assingment	13
10.	TIMING CHARACTERISTICS	14
10.1	LVDS interface	14
10.2	Display timing specifications	14
10.3	Power ON/OFF Sequence	16
11.	INSPECTION	17
12.	RELIABILITY TEST	17
13.	LEGAL INFORMATION	18
14.	CONTACT	19

3. MODULE CLASSIFICATION INFORMATION

RV	T	156	H	K	L	N	W	N	00
1.	2.	3.	4.	5.	6.	7.	8.	9.	10.

NO.	PARAMETER	SYMBOL
1.	BRAND	RV - Riverdi
2.	PRODUCT TYPE	T - TFT Standard
3.	DISPLAY SIZE	156 - 15.6"
4.	MODEL SERIAL NO.	H - High Brightness, IPS
5.	RESOLUTION	K - 1920 x 1080 px
6.	INTERFACE	L - LVDS
7.	FRAME	N - Without Mounting Metal Frame
8.	BACKLIGHT TYPE	W - LED White
9.	TOUCH PANEL	N - Without Touch Panel
10.	VERSION	00 - version

Revision:	Changes:	Date:
1.0	Initial Case	2025.05.13
1.1	Changed LED Diagram Circuit	2026.02.06

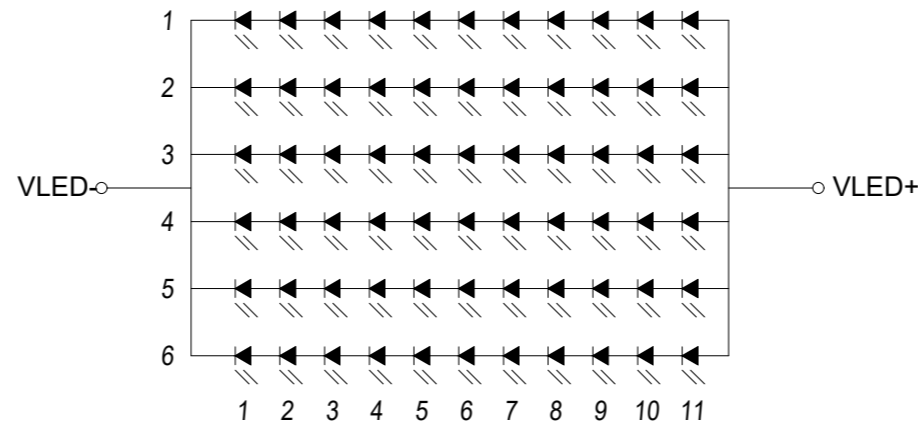
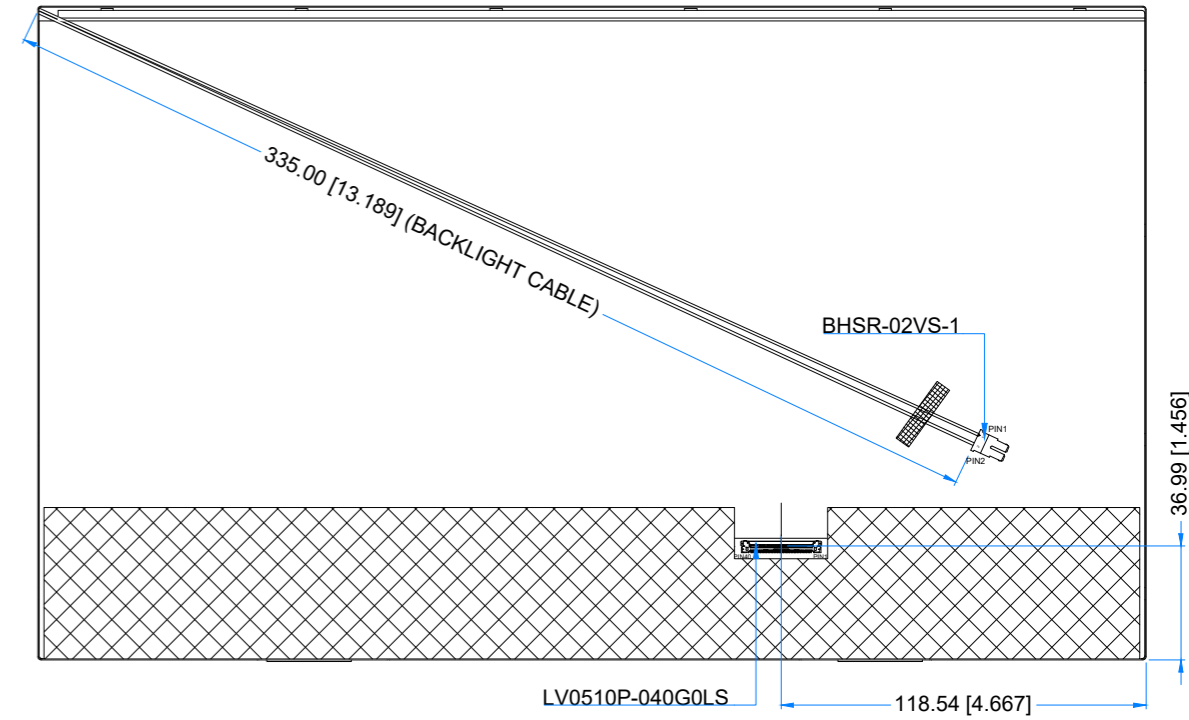
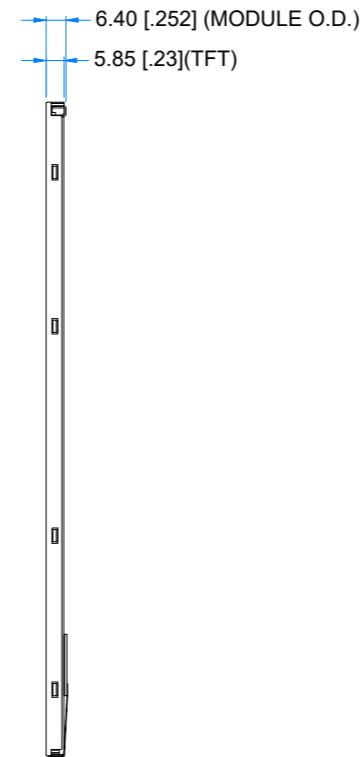
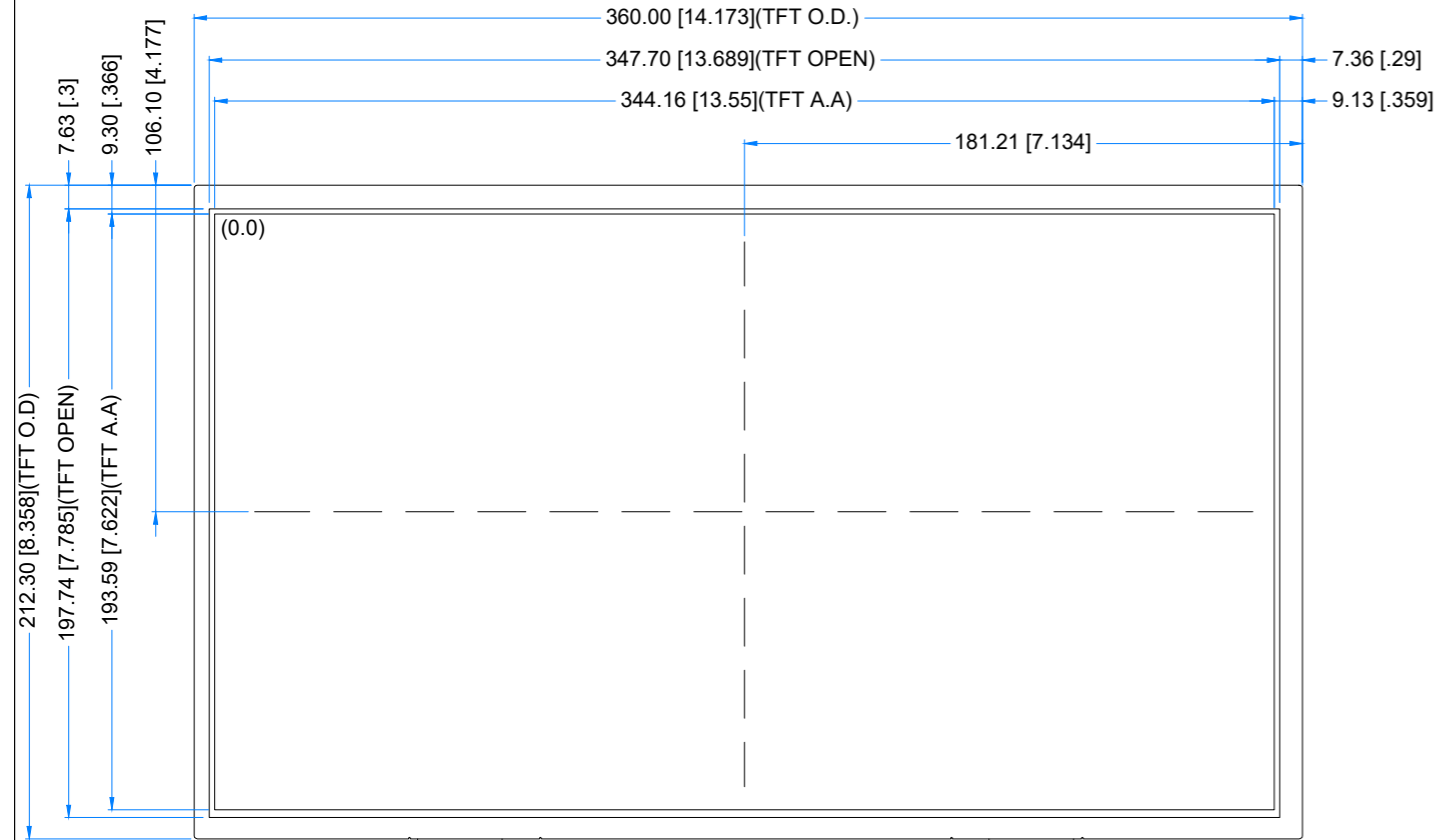

LED Diagram Circuit

TFT NOTES:
1. DISPLAY TYPE: TRANSMISSIVE, NORMALLY BLACK
2. RESOLUTION: 1920 x 1080
3. VIEWING ANGLE: FREE
4. DRIVING VOLTAGE: 3.3V
5. BACKLIGHT: 66 PCS LEDS, Vf=32.0V(typ.), If=300mA

GENERAL NOTES:
1. MODULE SURFACE LUMINANCE: 1000 cd/m²
2. OPERATING TEMPERATURE: -20°C ~ 70°C
3. STORAGE TEMPERATURE: -30°C ~ 80°C
4. WITHOUT INDIVIDUAL TOLERANCE: ±0.3mm
5. RoHS COMPLIANT

PN: RVT156HKLNWN00

SN:

DRAWN: M.Stabinski

2026.02.06

1:2.46

CHECKED: M.Wierzbowski

2026.02.06

[mm]

APPR: M.Wierzbowski

2026.02.06

ISO A3

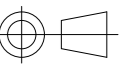

P. 1 of 1



5. ABSOLUTE MAXIMUM RATINGS

PARAMETER	SYMBOL	MIN	MAX	UNIT
Power Supply Voltage	V_{CC}	-0.3	4.0	V
Reference Voltage	V_{IN}	-0.3	$V_{CC}+0.3$	V
Operating Temperature	T_{OP}	-20	70	°C
Storage Temperature	T_{ST}	-30	80	°C

Note. The above are maximum values. If exceeded, they may cause permanent damage to the unit.

6. ELECTRICAL CHARACTERISTICS

PARAMETER	SYMBOL	MIN	TYP	MAX	UNIT
Power Supply Voltage	V_{CC}	3.0	3.3	3.6	V
Logic Input Voltage	V_{IH}	$0.7V_{CC}$	-	V_{CC}	V
	V_{IL}	0	-	$0.3V_{CC}$	V

7. BACKLIGHT ELECTRICAL CHARACTERISTICS

PARAMETER	SYMBOL	MIN	TYP	MAX	UNIT	NOTE
Backlight driving voltage	V_F	30.0	32.0	35.0	V	
Backlight driving current	I_F	-	300		mA	
Backlight Power Consumption	W_{BL}	-	9.6		W	
Lifetime	-	-	50,000	-	hours	Note 1

Note 1. Unless specified, the ambient temperature $T_a = 25^\circ\text{C}$, each LED, $I_f = 50\text{mA}$, $V_f = 3.2 \pm 0.2$ V.

Note 2. The recommended operating conditions refer to a range in which operation of this product is guaranteed. The operation cannot be guaranteed if the absolute maximum values exceed.

Note 3. If LED is driven by high current, high ambient temperature and humidity condition, the lifetime of LED will be reduced. Operating life means brightness goes down to 50% initial brightness. Typical operating lifetime is estimated data.

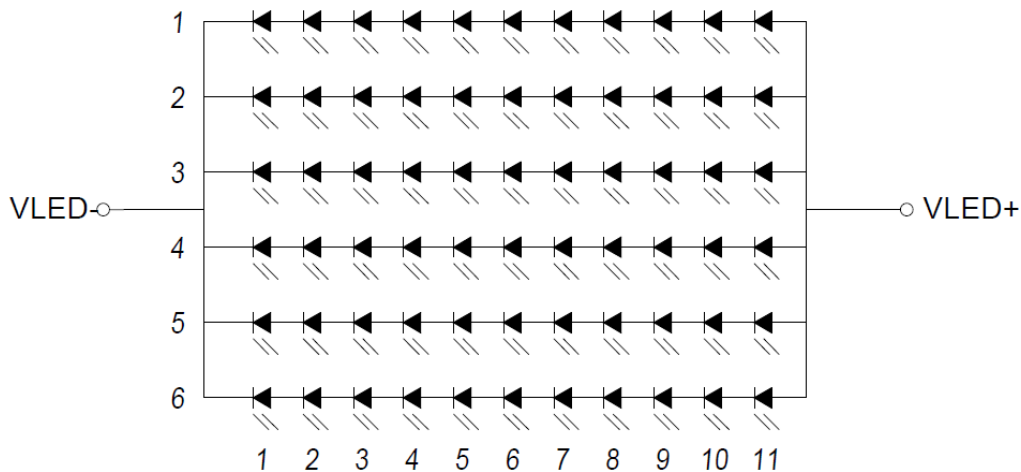

LED Diagram Circuit

8. ELECTRO-OPTICAL CHARACTERISTICS

ITEM	SYMBOL	CONDITION	MIN	TYP	MAX	UNIT	RMK	NOTE	
Response Time	Tr+Tf	$\theta=0^\circ$ $\phi=0^\circ$ Ta=25 °C	-	25	30	ms	FIG 1.	4, 7	
Contrast Ratio	Cr		800	1000	-	---	FIG 2.	1, 7	
Surface Luminance	Lv		900	1000	-	cd/m ²		2, 7	
Viewing Angle Range	θ	$\phi = 90^\circ$	80	85	-	deg	FIG 3.	6	
			$\phi = 270^\circ$	80	85	-			deg
			$\phi = 0^\circ$	80	85	-			deg
			$\phi = 180^\circ$	80	85	-			deg
CIE (x, y) Chromaticity	Rx	$\theta=0^\circ$ $\phi=0^\circ$ Ta=25 °C	0.562	0.602	0.642	-	FIG 2.	5,7	
	Ry		0.299	0.339	0.379	-			
	Gx		0.302	0.342	0.382	-			
	Gy		0.531	0.571	0.611	-			
	Bx		0.075	0.115	0.155	-			
	By		0.103	0.143	0.183	-			
	Wx		0.274	0.314	0.354	-			
	Wy		0.319	0.359	0.399	-			

Note 1. Contrast Ratio (CR) is defined mathematically as below, for more information see Figure 2.

$$\text{Contrast Ratio} = \frac{\text{Average Surface Luminance with all white pixels (P1, P2, P3, P4, P5)}}{\text{Average Surface Luminance with all black pixels (P1, P2, P3, P4, P5)}}$$

Note 2. Surface luminance is the LCD surface from the surface with all pixels displaying white. For more information see Figure 2.

$$L_v = \text{Average Surface Luminance with all white pixels (P1, P2, P3, P4, P5)}$$

Note 3. The uniformity in surface luminance δ WHITE is determined by measuring luminance at each test position 1 through 5 and then dividing the minimum luminance of 5 points luminance by maximum luminance of 5 points luminance. For more information see Figure 2.

$$\delta \text{ WHITE} = \frac{\text{Minimum Surface Luminance with all white pixels (P1, P2, P3, P4, P5)}}{\text{Maximum Surface Luminance with all white pixels (P1, P2, P3, P4, P5)}}$$

Note 4. Response time is the time required for the display to transition from white to black (Rise Time, Tr) and from black to white (Decay Time, Tf). For additional information see Figure 1. The test equipment is BM-7A.

Note 5. CIE (x, y) chromaticity, the x, y value is determined by measuring luminance at each test position 1 through 5, and then make average value.

Note 6. For TFT module, viewing angle is the angle at which the contrast ratio is greater 10. The angles are determined for the horizontal or x axis and the vertical or y axis with respect to the z axis which is normal to LCD surface. For more information see Figure 3.

Note 7. Viewing angle is measured at the center point of the LCD by CONOSCOPE (ergo-80). For response time testing, the testing data is based on BM-7A. Instruments for Contrast Ratio, Surface Luminance, Luminance Uniformity, Chromaticity the test data is based on SR-3A.

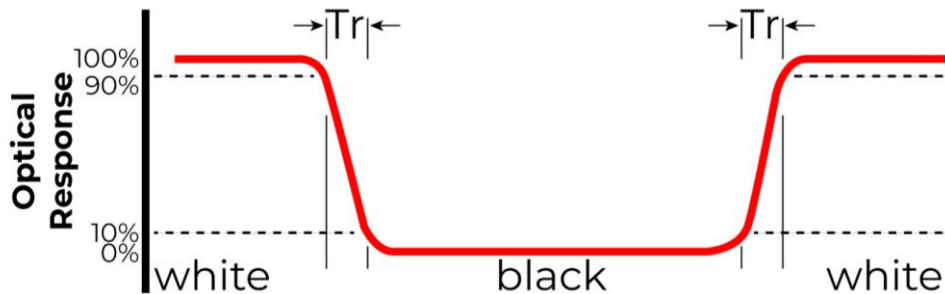

Figure 1. The definition of response time

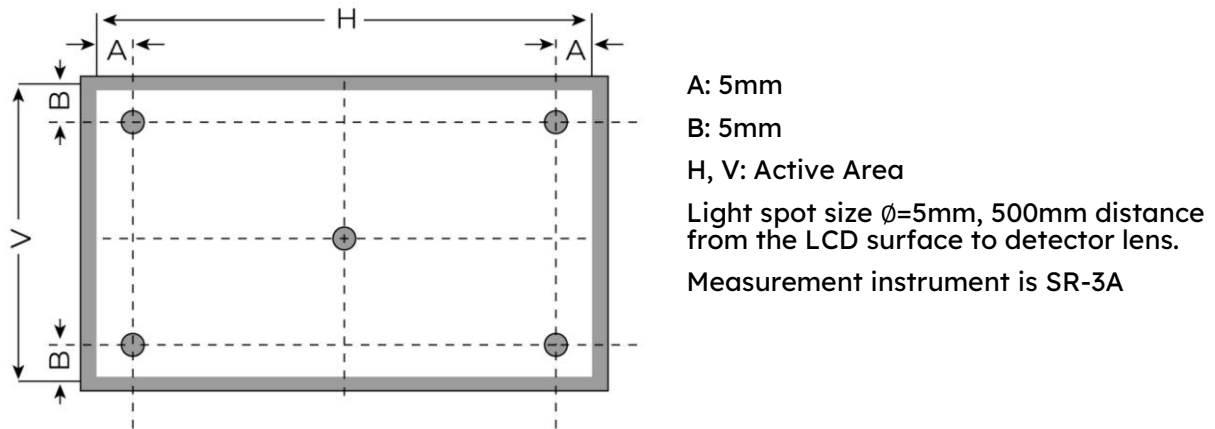

Figure 2. Measuring method for Contrast ratio, surface luminance, Luminance uniformity, CIE (x, y) chromaticity

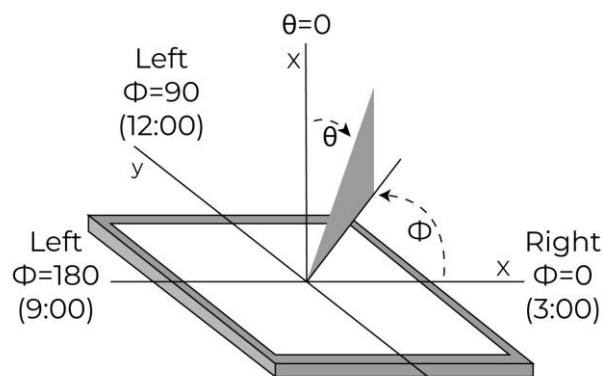

Figure 3. The definition of viewing angle

9. INTERFACES DESCRIPTION

9.1 TFT assingment

PIN	SYMBOL	I/O	DESCRIPTION	NOTE
1	RXO0-	I	Odd LVDS Negative Data Signal (-)	
2	RXO0+	I	Odd LVDS Positive Data Signal (+)	
3	RXO1-	I	Odd LVDS Negative Data Signal (-)	
4	RXO1+	I	Odd LVDS Positive Data Signal (+)	
5	RXO2-	I	Odd LVDS Negative Data Signal (-)	
6	RXO2+	I	Odd LVDS Positive Data Signal (+)	
7	GND	P	Ground	
8	RXOCLK-	I	Odd LVDS Negative Clock Signal (-)	
9	RXOCLK+	I	Odd LVDS Positive Clock Signal (+)	
10	GND	P	Ground	
11	RXO3-	I	Odd LVDS Negative Data Signal (-)	
12	RXO3+	I	Odd LVDS Positive Data Signal (+)	
13	GND	P	Ground	
14	RXE0-	I	Even LVDS Negative Data Signal (-)	
15	RXE0+	I	Even LVDS Positive Data Signal (+)	
16	RXE1-	I	Even LVDS Negative Data Signal (-)	
17	RXE1+	I	Even LVDS Positive Data Signal (+)	
18	RXE2-	I	Even LVDS Negative Data Signal (-)	
19	RXE2+	I	Even LVDS Positive Data Signal (+)	
20	GND	P	Ground	
21	RXECLK-	I	Even LVDS Negative Clock Signal (-)	

22	RXECLK+	I	Even LVDS Positive Clock Signal (+)	
23	GND	P	Ground	
24	RXE3-	I	Even LVDS Negative Data Signal (-)	
25	RXE3+	I	Even LVDS Positive Data Signal (+)	
26	GND	P	Ground	
27	V _{CC}	P	Power supply, 3.3V	
28	V _{CC}	P	Power supply, 3.3V	
29	BIST	I	LCD self-test Normal mode: NC or pull low; BIST mode: Pull high	
30-40	NC	-	No connection	

9.2 Backlight assingment

PIN	SYMBOL	DESCRIPTION	NOTE
1	VLED+	LEDA	Note 1
2	VLED-	LEDK	

Note 1. Backlight cable connector BHSR-02VS-1.

Matched Riverdi connector: RVA-0235-BHS

10. TIMING CHARACTERISTICS

10.1 LVDS interface

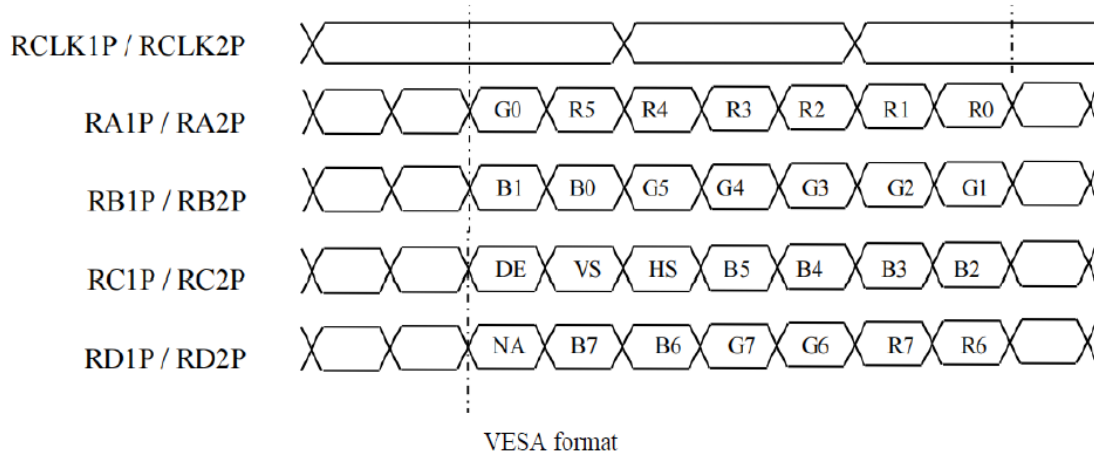

10.2 Display timing specifications

Timing Table (DE Mode Only)

SIGNAL	ITEM	SYMBOL	MIN	TYP	MAX	UNIT	NOTE
LVDS Receiver Clock	Frequency	Fclk (=1/TClk)	59.4	74.25	77.34	MHz	
	Input cycle to cycle jitter	Trcl	-	-	200	Ps	
	Spread spectrum modulation range	Fclk_mod	Fclk-2%	-	Fclk+2%	MHz	
	Spread spectrum modulation frequency	FSSM	60	-	200	KHz	
LVDS Receiver Data	Receiver Skew Margin	TRSM	-400	-	400	Ps	
Vertical Active Display Term	Frame Rate	F	48	60	62.5	Hz	
	Total	TV	1092	1125	1380	TH	TV = TVD + TVB
	Display	TVD		1080			

	Blank	TVB	12	45	300	TH	
Horizontal Active Display Term	Total	TH	1046	1100	1174	TCLK	TH = THD + THB
	Display	THD		960			960=1920/2port
	Blank	THB	86	140	214	TCLK	

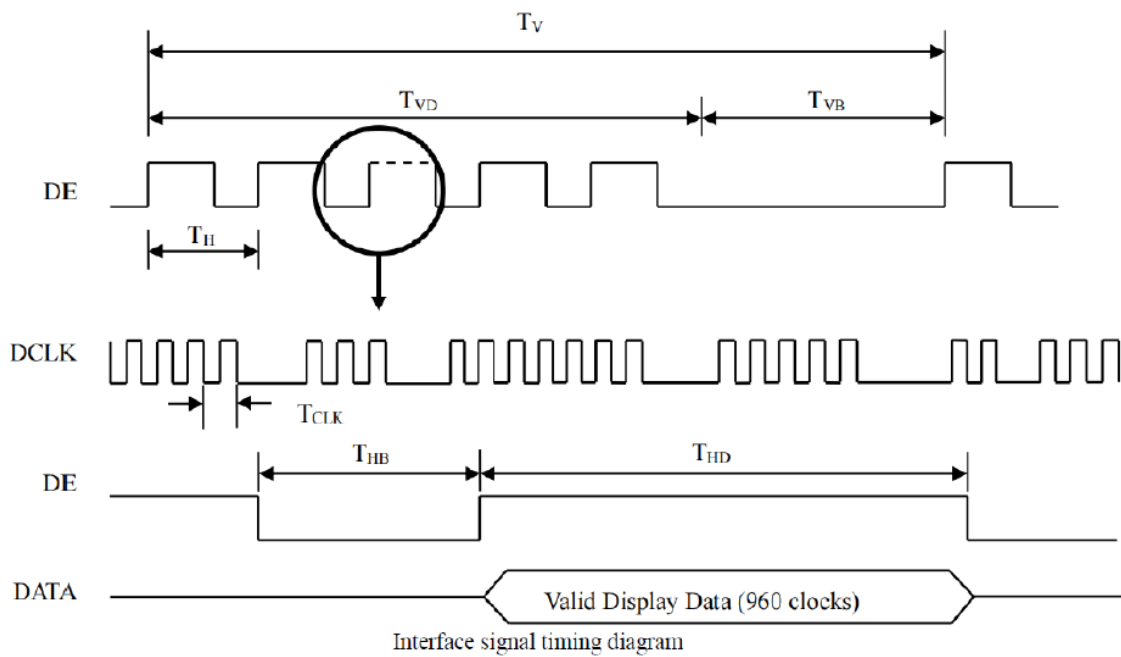

10.3 Power ON/OFF Sequence

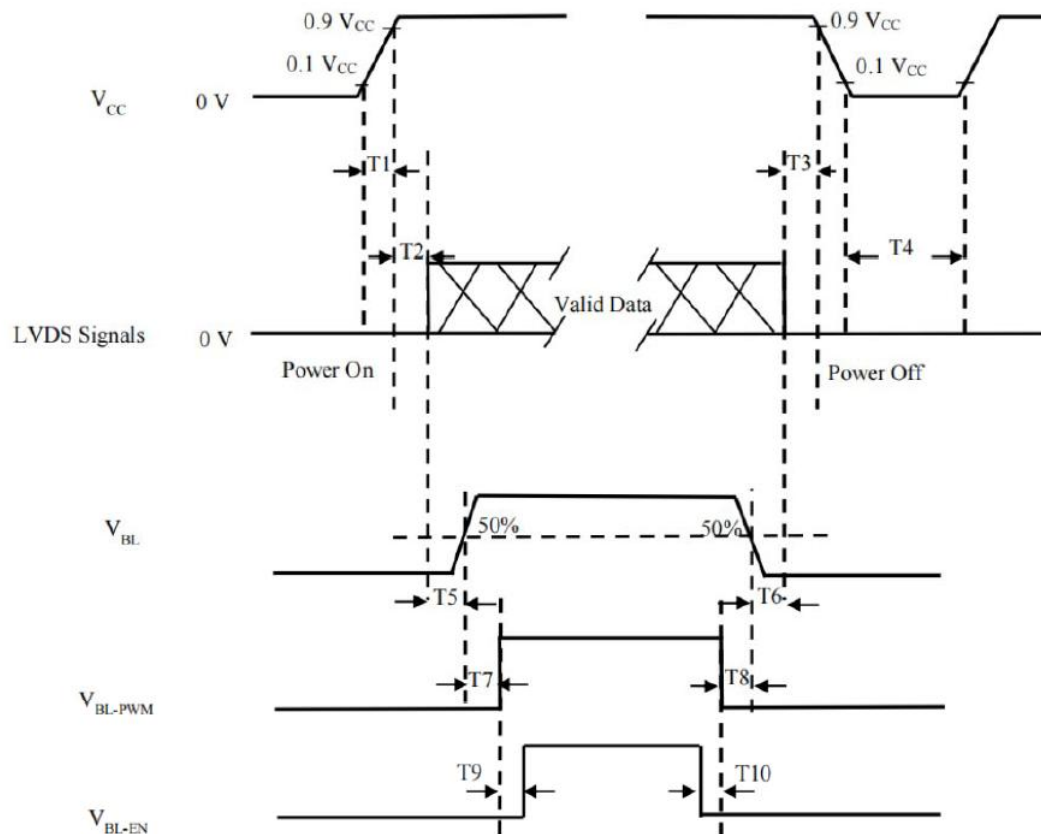

PARAMETER	MIN	TYP	MAX	UNIT
T1	0.5	-	10.0	ms
T2	0.0	50	200	ms
T3	0.0	50	200	ms
T4	1000.0	-		ms
T5	500.0	-		ms
T6	100.0	-		ms
T7	0	-		ms
T8	0	-		ms
T9	0	-		ms
T10	0	-		ms

11. INSPECTION

Standard acceptance/rejection criteria for TFT module according to document available [here](#).

12. RELIABILITY TEST

NO.	TEST ITEM	TEST CONDITION	NOTE
1	High Temperature Storage	80°C/120 hours	Note 1
2	Low Temperature Storage	-30°C/120 hours	
3	High Temperature Operating	70°C/120 hours	
4	Low Temperature Operating	-20°C/120 hours	
5	High Temperature and High Humidity	40°C, 90%RH, 120Hrs	
7	Thermal Cycling Test (No operation)	-20°C for 30min, 70°C for 30 min. 100 cycles. Then test at room temperature after 1 hour	Note 2
8	Vibration Test	Frequency: 10 ÷ 55 Hz. Stroke: 1.5 mm. Sweep: 10Hz ÷ 55Hz ÷ 10 Hz. 2 hours for each direction of X, Y, Z (Total 6 hours)	
9	Package Drop Test	Height: 60 cm 1 corner, 3 edges, 6 surfaces	

Note 1. Sample quantity for each test item is 5 ÷ 10 pcs.

Note 2. The device is kept at room temperature for 2 hours prior to starting the test

13. LEGAL INFORMATION

CE marking is usually obligatory only for a complete end product. Riverdi display modules are semi-finished goods which are used as inputs to become part of the finished products.

Therefore, Riverdi display modules are not CE marked.

This is not a standalone product. It was designed as an electronic component. It needs integration with a whole system to be fully functional.

Riverdi grants the guarantee for the proper operation of the goods for a period of 12 months from the date of possession of the goods. If in a consequence of this guaranteed execution the customer has received the defects-free item as replacement for the defective item, the effectiveness period of this guarantee shall start anew from the moment the customer receives the defects-free item.

Information about device is the property of Riverdi and may be the subject of patents pending or granted. It is not allowed to copy or disclosed this document without prior written permission.

Riverdi endeavors to ensure that all contained information in this document is correct but does not accept liability for any error or omission. Riverdi products are in developing process and published information may be not up to date. Riverdi reserves the right to update and makes changes to Specifications or written material without prior notice at any time. It is important to check the current position with Riverdi.

Images and graphics used in this document are only for illustrative the purpose. All images and graphics are possible to be displayed on the range products of Riverdi, however the quality may vary. Riverdi is no liable to the buyer or to any third party for any indirect, incidental, special, consequential, punitive, or exemplary damages (including without limitation lost profits, lost savings, or loss of business opportunity) relating to any product, service provided or to be provided by Riverdi, or the use or inability to use the same, even if Riverdi has been advised of the possibility of such damages.

Riverdi products are not fault tolerant nor designed, manufactured or intended for use or resale as on line control equipment in hazardous environments requiring fail-safe performance, such as in the operation of nuclear facilities, aircraft navigation or communication systems, air traffic control, direct life support machines or weapons systems in which the failure of the product could lead directly to death, personal injury or severe physical or environmental damage ('High-Risk Activities'). Riverdi and its suppliers specifically disclaim any expressed or implied warranty of fitness for High-Risk Activities. Using Riverdi products and devices in 'High-Risk Activities' and in any other application is entirely at the buyer's risk, and the buyer agrees to defend, indemnify and hold harmless Riverdi from all damages, claims or expenses resulting from such use. No licenses are conveyed, implicitly or otherwise, under any Riverdi intellectual property rights.

14. CONTACT

Your Success is Our Priority

Stuck on a technical challenge? Need expert guidance?
Our dedicated support team is just a message away.

Contact us at

contact@riverdi.com

We're here to ensure your project's success, every step of the way!