



TFT MODULE SPECIFICATION

RVT156HKHFWCA0-B

HB, IPS, HDMI 15.6" LCD TFT display datasheet
Rev. 1.2
2026-05-20

Riverdi Sp. z o.o.

Nowy Swiat 36
80-299 Gdansk, Poland
VAT ID: PL5842767153
Registration number (KRS): 0000923967

+48 587 703 116

Office hours: 9:00 to 17:30 CET (Mon-Fri)

contact@riverdi.com

riverdi.com

ITEM	CONTENTS	UNIT
LCD Type	TFT/Transmissive/Normally Black/IPS	/
Size	15.6	Inch
Viewing Direction	Free	/
Outside Dimensions (W x H x D)	385.20 x 214.40 x 22.05	mm
Active Area (W x H)	345.76 x 195.19	mm
Pixel Pitch (W x H)	0.1793 x 0.1793	mm
Resolution	1920 x 1080	/
Brightness	850	cd/m ²
Color Depth	16.7 M	/
Pixel Arrangement	RGB Vertical Stripe	/
Controller of the main board	RTD2555T	/
Interface	HDMI	/
With/Without Touch	With Projected Capacitive Touch Panel	/
CTP Driver	ILI2510	/
Touch Panel Interface	USB-C	/
Power Supply	Power Jack (6.0-27.0V)	V
Weight	1614	g

Note 1. RoHS3 compliant

Note 2. LCM weight tolerance: ± 5%.

1. REVISION RECORD

REV NO.	REV DATE	CONTENTS	REMARKS
1.0	2025-09-02	Initial release	
1.1	2026-02-02	PCBA position update	
1.2	2026-05-20	Drawing update, details described in drawing revision	

2. CONTENTS

1.	REVISION RECORD	3
2.	CONTENTS	4
3.	MODULE CLASSIFICATION INFORMATION	5
4.	ASSEMBLY	6
4.1	Mounting Frame	6
5.	MODULE DRAWING	7
6.	ABSOLUTE MAXIMUM RATINGS	8
7.	ELECTRICAL CHARACTERISTICS	8
8.	BACKLIGHT ELECTRICAL CHARACTERISTICS	9
9.	ELECTRO-OPTICAL CHARACTERISTICS	10
10.	INTERFACES DESCRIPTION	13
10.1	PCB overview	13
10.2	Touch panel connector USB-C	14
10.3	Power connector - DC1	14
10.4	HDMI - JP1	15
10.5	External keyboard - J1	16
10.6	Backlight PWM & Power - J5	16
10.7	Uart - J2	17
11.	DISPLAY SPECIFICATION	17
12.	CaPACITIVE TOUCH SCREEN PANEL SPECIFICATIONS	18
12.1	Mechanical characteristics	18
12.2	Electrical characteristics	18
13.	INSPECTION	19
13.1	Inspection condition	19
14.	RELIABILITY TEST	20
15.	LEGAL INFORMATION	21
16.	CONTACT	22

3. MODULE CLASSIFICATION INFORMATION

RV	T	156	H	K	H	F	W	C	A0	B
1.	2.	3.	4.	5.	6.	7.	8.	9.	10.	11.

NO.	PARAMETER	SYMBOL
1.	BRAND	RV - Riverdi
2.	PRODUCT TYPE	T - TFT Standard
3.	DISPLAY SIZE	156 - 15.6"
4.	MODEL SERIAL NO.	H - High Brightness, IPS
5.	RESOLUTION	K - 1920 x 1080 px
6.	INTERFACE	H - HDMI
7.	FRAME	F - With Mounting Metal Frame
8.	BACKLIGHT TYPE	W - LED White
9.	TOUCH PANEL	C - with Capacitive Touch Panel
10.	VERSION	A0 - aTouch
11.	BONDING TECHNOLOGY	B - Optical bonding

4. ASSEMBLY

4.1 Mounting Frame

For dimensions 3.5", 4.3", 5.0", 7.0", 10.1", 12.1" and 15.6", the product with mounting frame version is available. Thanks to the four catches attached to the side, frame provides strong assembly to the surface by mounting element (like the screw, see Figure 1). The frames are specially designed to fit Riverdi products perfectly. The diameter of the mounting hole is 3.5mm.

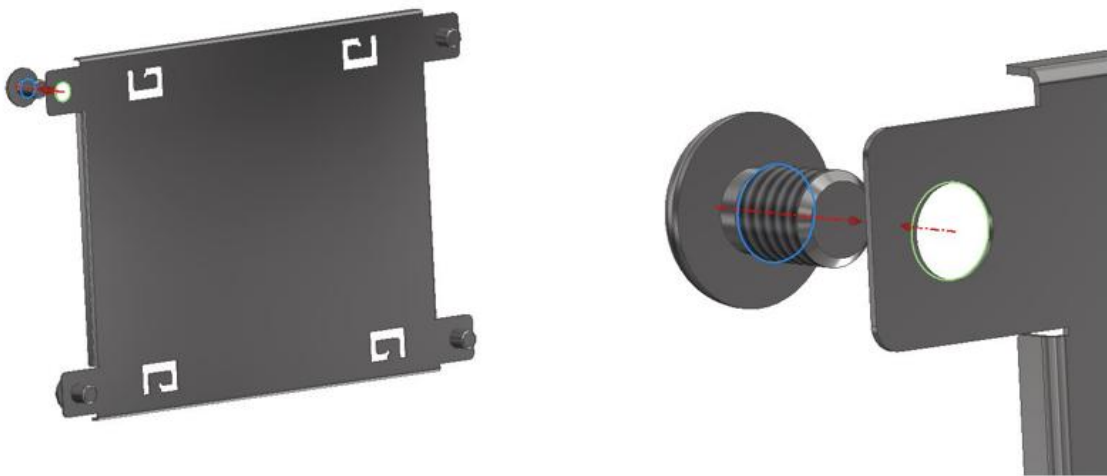
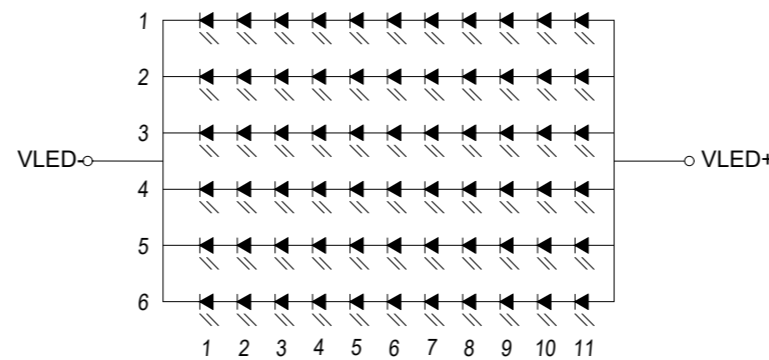
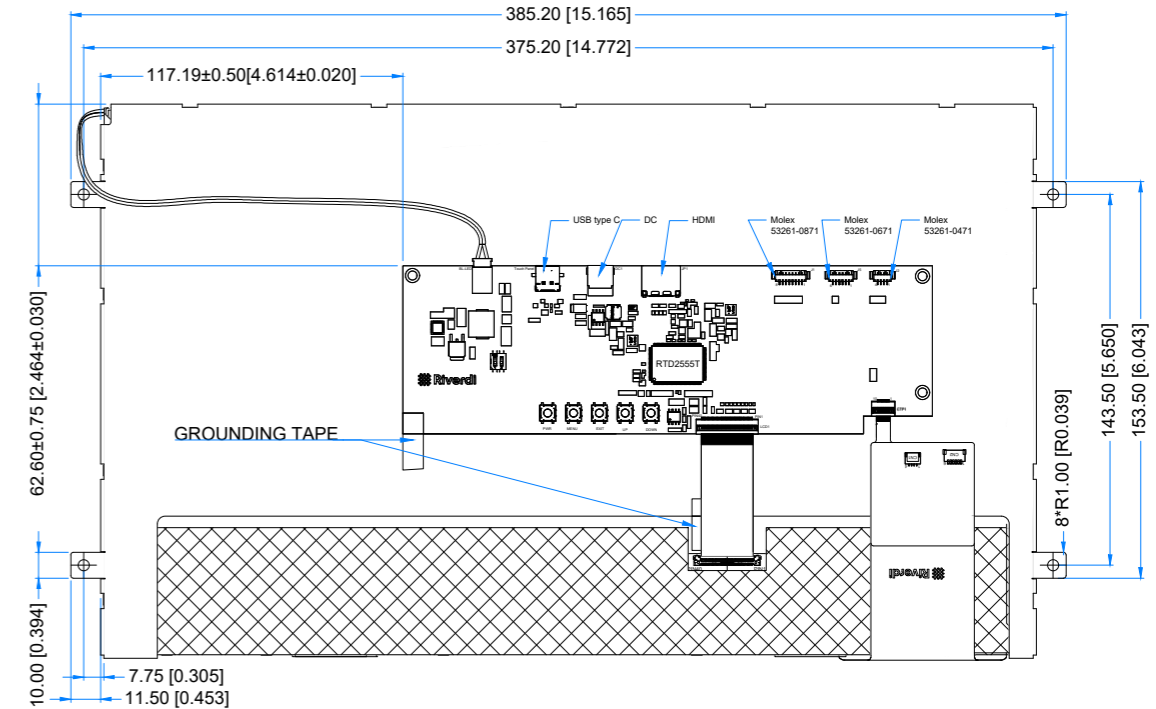
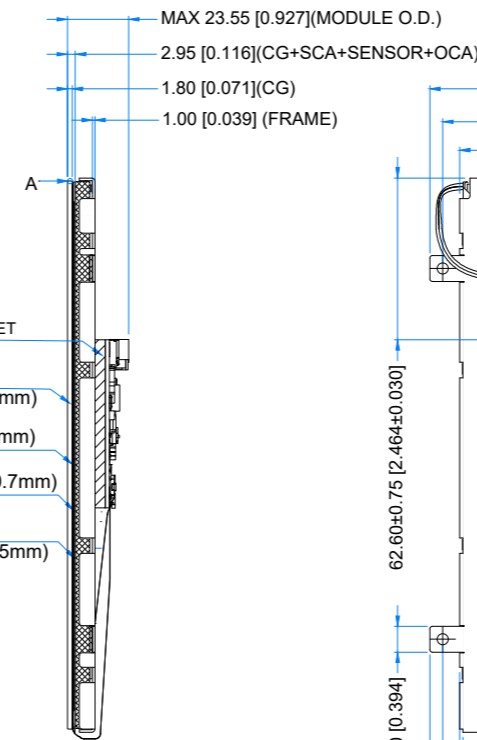
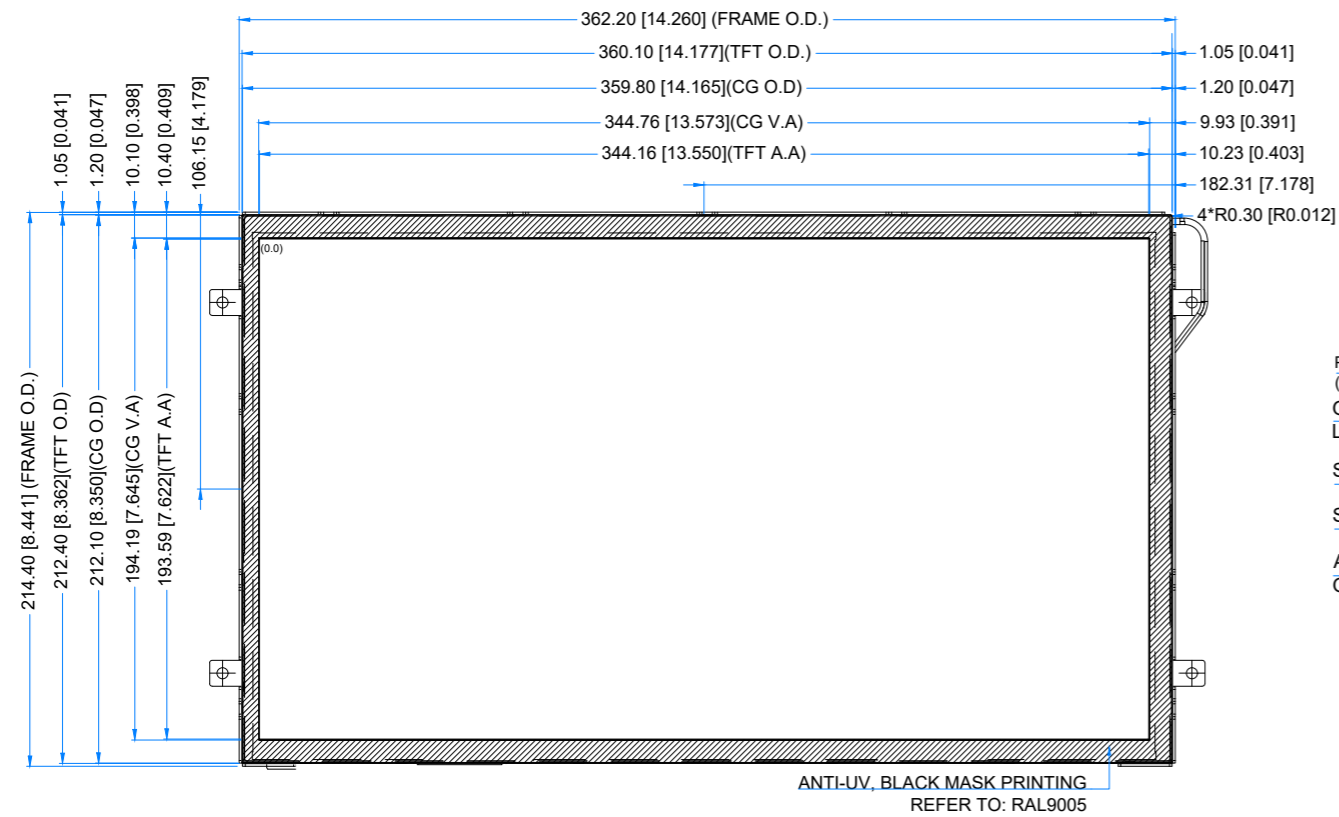

Figure 1. Mounting Frame

Revision:	Changes:	Date:
1.0	Initial Case	2025.09.02
1.1	PCBA Position & Gasket Change	2026.01.29
1.2	ECO_000398, Addition Of Second Grounding Tape	2026.02.26
1.3	Updated Front View, Addition Of Cover Glass Detailed View	2026.05.20



LED Diagram Circuit

DETAIL A
SCALE 4:1

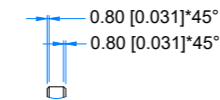

LCM NOTES:
1. LCD TYPE: TRANSMISSIVE, NORMALLY BLACK, IPS
2. RESOLUTION: 1920x1080
3. VIEWING ANGLE: FREE
4. CONTROLLER IC OF MAIN BOARD: RTD2555T
5. VIDEO INTERFACE: HDMI
6. POWER SUPPLY: POWER JACK (6.0-27.0V)
7. MODULE SURFACE LUMINANCE: 850cd/m²

TP NOTES:
1. TP STRUCTURE: G+G
2. CG THICKNESS: 1.8mm[0.071inch]
3. SURFACE HARDNESS: 6H
4. DRIVER IC: ILI2510
5. INTERFACE: USB-C

GENERAL NOTES:
1. OPERATING TEMPERATURE: -20°C ~ 70°C
2. STORAGE TEMPERATURE: -30°C ~ 80°C
3. WITHOUT INDIVIDUAL TOLERANCE:
±0.3mm[0.012inch]
4. RoHS3 COMPLIANT

PN: RVT156HKHFCA0-B

SN:

DRAWN: M.Stabinski

2026.05.20

1:2.93

CHECKED: M.Wierzbowski

2026.05.20

[mm]

APPR: M.Wierzbowski

2026.05.20

ISO A3

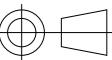

6. ABSOLUTE MAXIMUM RATINGS

PARAMETER	SYMBOL	MIN	MAX	UNIT
Supply Voltage for Module	V_{DD}	5.0	27.0	V
Operating Temperature	T_{OP}	-20	70	°C
Storage Temperature	T_{ST}	-30	80	°C

Note. The above are maximum values. If exceeded, they may cause permanent damage to the unit.

7. ELECTRICAL CHARACTERISTICS

PARAMETER	SYMBOL	MIN	TYP	MAX	UNIT	NOTE
Supply Voltage for Module	V_{DD}	6.0	12.0	27.0	V	

PARAMETER	SYMBOL	BL 0%	BL 50%	BL 100%	UNIT	NOTE
Current drawn from $V_{DD}@6.0V$	I_{VDD}	605	1522	2642	mA	Note 1
Current drawn from $V_{DD}@12.0V$		306	680	1092	mA	
Current drawn from $V_{DD}@27.0V$		153	308	464	mA	

Note 1.

BL 0%, current was measured with BL brightness set to 0%,
 BL 50%, current was measured with BL brightness set to 50%,
 BL 100%, current was measured with BL brightness set to 100%.

8. BACKLIGHT ELECTRICAL CHARACTERISTICS

PARAMETER	SYMBOL	MIN	TYP	MAX	UNIT	NOTE
Backlight Power Consumption	WBL	-	9.6	-	W	
Lifetime	-	-	50,000	-	hours	Note 1

Note 1. Unless specified, the ambient temperature $T_a = 25^{\circ}\text{C}$

Note 2. The recommended operating conditions refer to a range in which operation of this product is guaranteed. The operation cannot be guaranteed if the absolute maximum values exceed.

Note 3. If LED is driven by high current, high ambient temperature and humidity condition, the lifetime of LED will be reduced. Operating life means brightness goes down to 50% initial brightness. Typical operating lifetime is estimated data.

9. ELECTRO-OPTICAL CHARACTERISTICS

ITEM	SYMBOL	CONDITION	MIN	TYP	MAX	UNIT	RMK	NOTE
Response Time	Tr+Tf	$\theta=0^\circ$ $\phi=0^\circ$ Ta=25 °C	-	25	30	ms	FIG 2.	4, 7
Contrast Ratio	Cr		800	1000	-	---	FIG 3.	1, 7
Surface Luminance	Lv		-	850	-	cd/m ²		2, 7
Viewing Angle Range	θ	$\phi = 90^\circ$ $\phi = 270^\circ$ $\phi = 0^\circ$ $\phi = 180^\circ$	80	85	-	deg	FIG 4.	6
			80	85	-	deg		
			80	85	-	deg		
			80	85	-	deg		
CIE (x, y) Chromaticity	Rx	$\theta=0^\circ$ $\phi=0^\circ$ Ta=25 °C	0.562	0.602	0.642	-	FIG 3.	5,7
	Ry		0.299	0.339	0.379	-		
	Gx		0.302	0.342	0.382	-		
	Gy		0.531	0.571	0.611	-		
	Bx		0.075	0.115	0.155	-		
	By		0.103	0.143	0.183	-		
	Wx		0.274	0.314	0.354	-		
	Wy		0.319	0.359	0.399	-		

Note 1. Contrast Ratio (CR) is defined mathematically as below, for more information see Figure 2.

$$\text{Contrast Ratio} = \frac{\text{Average Surface Luminance with all white pixels (P1, P2, P3, P4, P5)}}{\text{Average Surface Luminance with all black pixels (P1, P2, P3, P4, P5)}}$$

Note 2. Surface luminance is the LCD surface from the surface with all pixels displaying white. For more information see Figure 2.

$$L_v = \text{Average Surface Luminance with all white pixels (P1, P2, P3, P4, P5)}$$

Note 3. The uniformity in surface luminance δ WHITE is determined by measuring luminance at each test position 1 through 5, and then dividing the minimum luminance of 5 points luminance by maximum luminance of 5 points luminance. For more information see Figure 2.

$$\delta \text{ WHITE} = \frac{\text{Minimum Surface Luminance with all white pixels (P1, P2, P3, P4, P5)}}{\text{Maximum Surface Luminance with all white pixels (P1, P2, P3, P4, P5)}}$$

Note 4. Response time is the time required for the display to transition from white to black (Rise Time, T_r) and from black to white (Decay Time, T_f). For additional information see Figure 1. The test equipment is BM-7A.

Note 5. CIE (x, y) chromaticity, the x, y value is determined by measuring luminance at each test position 1 through 5, and then make average value.

Note 6. For TFT module, viewing angle is the angle at which the contrast ratio is greater 10. The angles are determined for the horizontal or x axis and the vertical or y axis with respect to the z axis which is normal to LCD surface. For more information see Figure 3.

Note 7. Viewing angle is measured at the center point of the LCD by CONOSCOPE (ergo-80). For response time testing, the testing data is based on BM-7A. Instruments for Contrast Ratio, Surface Luminance, Luminance Uniformity, Chromaticity the test data is based on SR-3A.

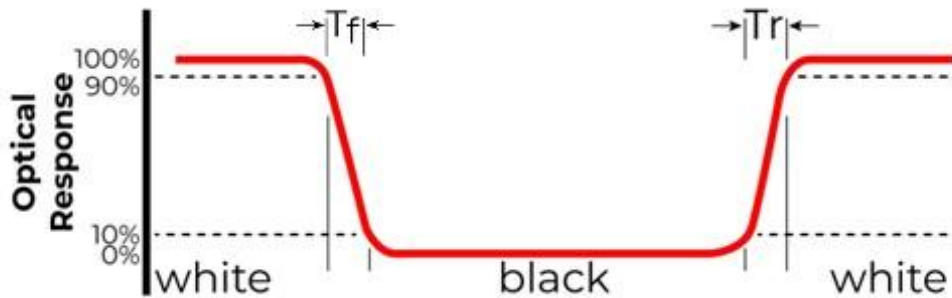

Figure 2. The definition of response time

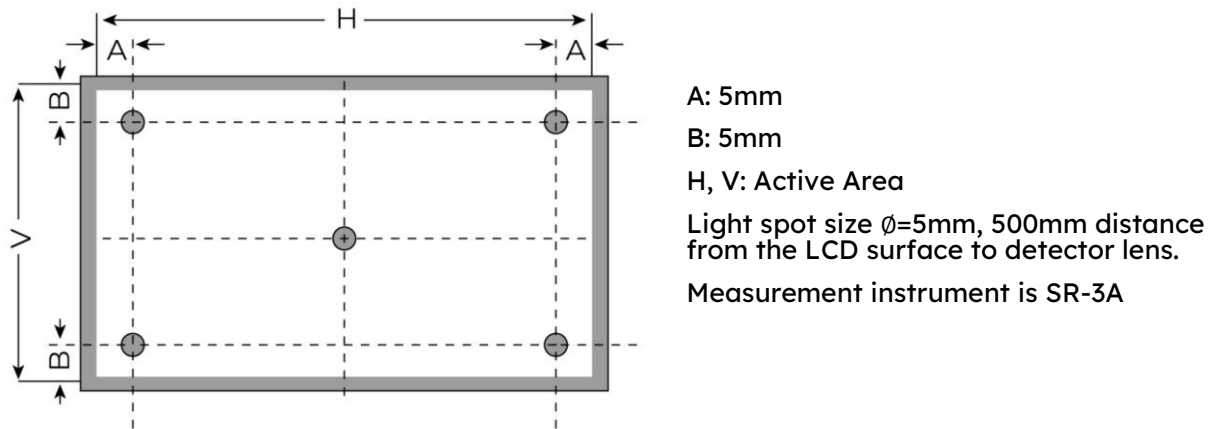

Figure 3. Measuring method for Contrast ratio, surface luminance, Luminance uniformity, CIE (x, y) chromaticity

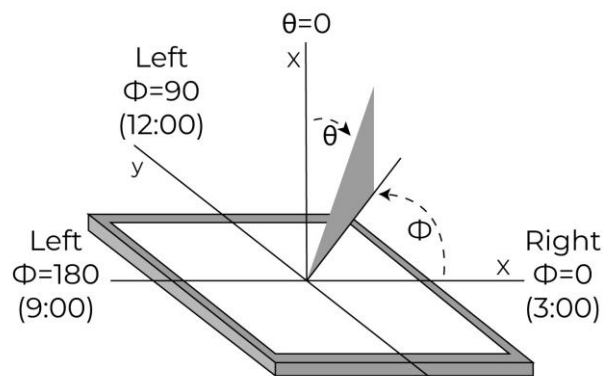
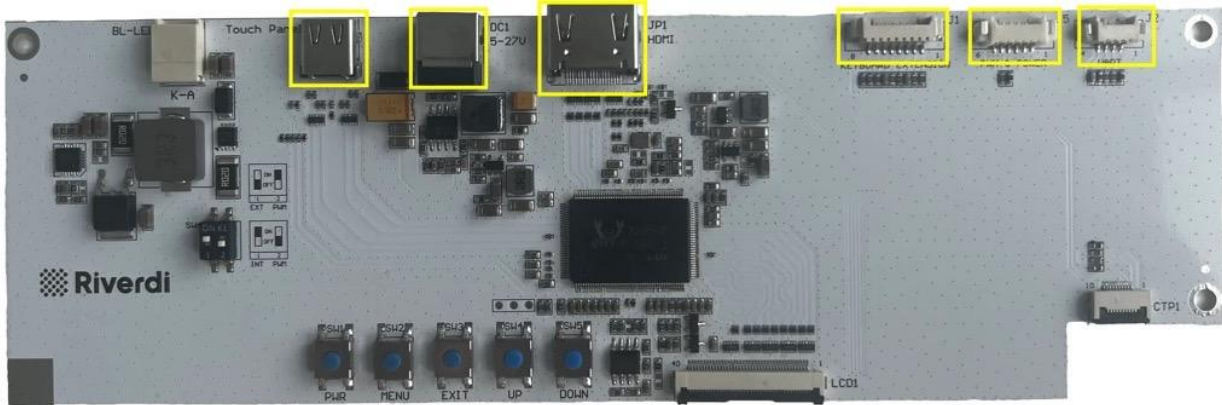

Figure 4. The definition of viewing angle

10. INTERFACES DESCRIPTION

10.1 PCB overview



NAME	CONNECTOR	DESCRIPTION	NOTE
TOUCH PANEL	USB-C	Video interface/Touch panel interface	
DC1	Power Jack	DC Jack, (5.5mm OD; 2.1 mm ID) This is the connector to power on the TFT module. It allows DC for voltage range from 6.0V to 27.0V.	
JP1	HDMI connector	This is the connector which you can connect the HDMI signal source to the module	
J1	External keyboard connector	Molex 53261-0871 or alternative; Horizontal, 1.25mm pitch; 8 pins. The connector is reserved for external keyboard. Performs the same functions: PWR, MENU, EXIT, UP, DOWN as the push buttons on PCB.	Note 1
J5	Backlight PWM & Power	Molex 53261-0671 or alternative; Horizontal, 1.25mm pitch; 6 pins. The unit realizes the function of digital dimming. This connector enables to control backlight PWM externally.	Note 2
J2	UART	Molex 53261-0471 or alternative; Horizontal, 1.25mm pitch; 4 pins TBD, future development	

Note 1. External keyboards are optional, not included in the standard kit.

Note 2. 4 position-DIP onboard switch SW6 is used to choose the power to backlight.

The settings are:

INTERNAL BL PWM: Set 1&2 to OFF, and 3&4 to ON,

EXTERNAL BL PWM: Set 1&2 to ON, and 3&4 to OFF.

10.2 Touch panel connector USB-C

PIN	SYMBOL	DESCRIPTION
A4/B4	VBUSA/VBUSB	Power supply, 5.0V
A9/B9	VBUSA/VBUSB	Power supply, 5.0V
A2/B2	SSTXP1/SSTXP2	Super speed differential pair transmit positive
A3/B3	SSTXN1/SSTXN2	Super speed differential pair transmit negative
A5/B5	CC1/CC2	Configuration channel
A6/B6	DP1/DP2	Differential pair positive
A7/B7	DN1/DN2	Differential pair negative
A8/B8	SBU1/SBU2	Sideband use
A10/B10	SSRXN2/SSRXN1	Super speed differential pair receive positive
A11/B11	SSRXP2/SSRXP1	Super speed differential pair receive positive
A1/B1	GND	Ground
A12/B12	GND	Ground

Note 1. All the signals in Touch panel connector are in accordance with USB-C standard.

Note 2. Matched Riverdi cable accessory: USB-A 2.0 TO USB-C CABLE

10.3 Power connector – DC1

PIN	SYMBOL	DESCRIPTION
1	VDD	Power supply DC, 6.0V-27.0V
2	GND	Ground

10.4 HDMI – JP1

PIN	SYMBOL	DESCRIPTION
1	TMDS Data 2+	TMDS differential signal 2+
2	TMDS Data2 Shield	Data2 shielding ground
3	TMDS Data 2-	TMDS differential signal 2-
4	TMDS Data 1+	TMDS differential signal 1+
5	TMDS Data1 Shield	Data1 shielding ground
6	TMDS Data 1-	TMDS differential signal 1-
7	TMDS Data 0+	TMDS differential signal 0+
8	TMDS Data 0 Shield	Data0 shielding ground
9	TMDS Data 0-	TMDS differential signal 0-
10	TMDS Data Clock+	TMDS differential signal Clock+
11	TMDS Data Shield	Clock shielding ground
12	TMDS Data Clock-	TMDS differential signal Clock-
13	CEC	Electronic protocol CEC
14	NC	No Connection
15	SCL	I ² C clock Line
16	SDA	I ² C data Line
17	DDC/CEC GND	Data display channel
18	+5V	HDMI 5V
19	Hot Plug Detect	Hot plug Detect

Note 1. Matched Riverdi 4K HDMI cable accessory: 4K HDMI CABLE

10.5 External keyboard – J1

PIN	SYMBOL	DESCRIPTION
1	Down	Page down
2	Up	Page up
3	Exit	Exit
4	Menu	Menu
5	PWR	Power on/off
6	LED_EN	LED Enable; Output signal 3.3V
7	GND	Ground
8	Keyboard VDD	Keyboard VDD; Output 3.3V

Note 1. Matched Riverdi cable accessory: RVA-0108M-1.25FF-1.

10.6 Backlight PWM & Power – J5

PIN	SYMBOL	DESCRIPTION	NOTE
1	GND	Ground	
2	GND	Ground	
3	EN	Backlight enable, active H	
4	PWM	PWM input; 3.3V	Note 1
5	VDD	Power supply, 6.0-27.0V	Note 2
6	VDD	Power supply, 6.0-27.0V	Note 2

Note 1. PWM frequency range: 0.1kHz - 20kHz.

100% PWM duty cycle corresponds to maximum brightness

0% PWM duty cycle corresponds to minimum brightness

Note 2. Matched Riverdi cable accessory: RVA-0106M-1.25FF-1.

10.7 UART – J2

PIN	SYMBOL	DESCRIPTION	NOTE
1	GND	Ground	
2	UART_RX	UART RX	
3	UART_TX	UART TX	
4	VCC	3.3V	

Note Matched Riverdi cable accessory: RVA-0104M-1.25FF

11. DISPLAY SPECIFICATION

The TFT of the module applies Riverdi high brightness, IPS, 15.6” LVDS: RVT156HKLFWCA0-B

The supported resolution of the display in this module is 1920*1080.

For detailed information, please refer to datasheet of display.

12. CAPACITIVE TOUCH SCREEN PANEL SPECIFICATIONS

12.1 Mechanical characteristics

DESCRIPTION	SPECIFICATION	REMARK
Touch Panel Size	15.6 inch	αTouch
Outline Dimension of CTP	385.20 mm x 214.40 mm	
Product Thickness	2.95 mm	
Glass Thickness	1.8 mm	
CTP View Area	344.16 mm x 193.59 mm	
Sensor Active Area	345.76 mm x 194.19 mm	
Surface Hardness	6H	

12.2 Electrical characteristics

DESCRIPTION	SPECIFICATION	REMARK
Linearity	+/-1.5mm	
Controller	ILI2510	
Resolution	1920 x 1080	

13. INSPECTION

Standard acceptance/rejection criteria for TFT module according to document available [here](#).

13.1 Inspection condition

Ambient conditions:

- Temperature: $25 \pm 2^\circ\text{C}$
- Humidity: $(60 \pm 10) \%RH$
- Illumination: Single fluorescent lamp non-directive (300 to 700 lux)

Viewing distance: $35 \pm 5\text{cm}$ between inspector bare eye and LCD.

Viewing Angle: U/D: $45^\circ/45^\circ$, L/R: $45^\circ/45^\circ$

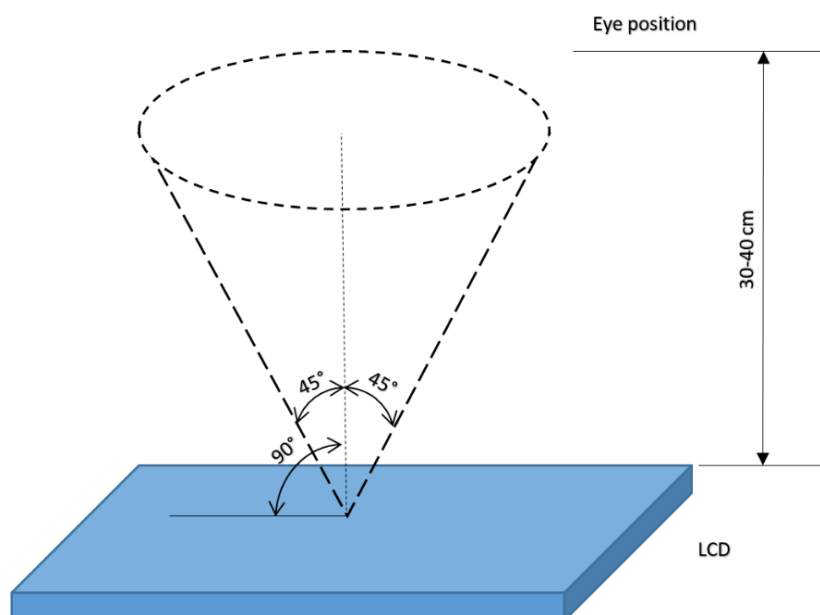

14. RELIABILITY TEST

NO.	TEST ITEM	TEST CONDITION	NOTE
1	High Temperature Storage	80°C/120 hours	Note 1
2	Low Temperature Storage	-30°C/120 hours	
3	High Temperature Operating	70°C/120 hours	
4	Low Temperature Operating	-20°C/120 hours	
5	High Temperature and High Humidity	40°C, 90%RH, 120Hrs	
6	Thermal Cycling Test (No operation)	-20°C for 30min, 70°C for 30 min. 100 cycles. Then test at room temperature after 1 hour	Note 2
7	Vibration Test	Frequency: 10 ÷ 55 Hz. Stroke: 1.5 mm. Sweep: 10Hz ÷ 55Hz ÷ 10 Hz. 2 hours for each direction of X, Y, Z (Total 6 hours)	
8	Package Drop Test	Height: 60 cm 1 corner, 3 edges, 6 surfaces	

Note 1. Sample quantity for each test item is 5 ÷ 10 pcs.

Note 2. The device is kept at room temperature for 2 hours prior to starting the test

15. LEGAL INFORMATION

CE marking is usually obligatory only for a complete end product. Riverdi display modules are semi-finished goods which are used as inputs to become part of the finished products.

Therefore, Riverdi display modules are not CE marked.

This is not a standalone product. It was designed as an electronic component. It needs integration with a whole system to be fully functional.

Riverdi grants the guarantee for the proper operation of the goods for a period of 12 months from the date of possession of the goods. If in a consequence of this guaranteed execution the customer has received the defects-free item as replacement for the defective item, the effectiveness period of this guarantee shall start anew from the moment the customer receives the defects-free item.

Information about device is the property of Riverdi and may be the subject of patents pending or granted. It is not allowed to copy or disclosed this document without prior written permission.

Riverdi endeavors to ensure that all contained information in this document is correct but does not accept liability for any error or omission. Riverdi products are in developing process and published information may be not up to date. Riverdi reserves the right to update and makes changes to Specifications or written material without prior notice at any time. It is important to check the current position with Riverdi.

Images and graphics used in this document are only for illustrative the purpose. All images and graphics are possible to be displayed on the range products of Riverdi, however the quality may vary. Riverdi is no liable to the buyer or to any third party for any indirect, incidental, special, consequential, punitive, or exemplary damages (including without limitation lost profits, lost savings, or loss of business opportunity) relating to any product, service provided or to be provided by Riverdi, or the use or inability to use the same, even if Riverdi has been advised of the possibility of such damages.

Riverdi products are not fault tolerant nor designed, manufactured or intended for use or resale as on line control equipment in hazardous environments requiring fail-safe performance, such as in the operation of nuclear facilities, aircraft navigation or communication systems, air traffic control, direct life support machines or weapons systems in which the failure of the product could lead directly to death, personal injury or severe physical or environmental damage ('High-Risk Activities'). Riverdi and its suppliers specifically disclaim any expressed or implied warranty of fitness for High-Risk Activities. Using Riverdi products and devices in 'High-Risk Activities' and in any other application is entirely at the buyer's risk, and the buyer agrees to defend, indemnify and hold harmless Riverdi from all damages, claims or expenses resulting from such use. No licenses are conveyed, implicitly or otherwise, under any Riverdi intellectual property rights.

16. CONTACT

Your Success is Our Priority

Stuck on a technical challenge? Need expert guidance?
Our dedicated support team is just a message away.

Contact us at

contact@riverdi.com

We're here to ensure your project's success, every step of the way!