



TFT MODULE SPECIFICATION

## **RVT156HKDFWN00**

MIPI DSI, IPS 15.6" FULL HD LCD TFT display datasheet  
Rev. 1.3  
2026-05-06

---

**Riverdi Sp. z o.o.**

Nowy Swiat 36  
80-299 Gdansk, Poland  
VAT ID: PL5842767153  
Registration number (KRS): 0000923967

**+48 587 703 116**

Office hours: 9:00 to 17:30 CET (Mon-Fri)

**[contact@riverdi.com](mailto:contact@riverdi.com)**

**[riverdi.com](http://riverdi.com)**



ITEM	CONTENTS	UNIT
LCD Type	TFT/Transmissive/Normally Black/IPS	/
Size	15.6	Inch
Viewing Direction	All	/
Outside Dimensions (W x H x D)	385.10 x 214.50 x 14.56	mm
Active Area (W x H)	344.16 x 193.59	mm
Pixel Pitch (W x H)	0.1793 x 0.1793	mm
Resolution	1920 x 1080	/
Brightness	1000	cd/m <sup>2</sup>
Color Depth	16.7 M	/
Pixel Arrangement	RGB Vertical Stripe	/
Driver IC of Board	SN65DSI84	
Interface	MIPI DSI	/
EEPROM Memory size	2-Kbit	
Host Connector	ZIF 34 pins, 0.5mm pitch, down-side contact	/
With/Without Touch Panel	With Projected Capacitive Touch Panel	/
CTP Driver	ILI2510	/
Bonding Technology	Optical Bonding	/
Weight	1096	g

**Note 1.** RoHS3 compliant

**Note 2.** LCM weight tolerance:  $\pm 5\%$ .

## 1. REVISION RECORD

REV NO.	REV DATE	CONTENTS	REMARKS
1.0	2025-06-27	Initial release	
1.1	2025-09-15	Change of PCBA position on drawing.	
1.2	2026-02-02	Drawing updated	
1.3	2026-05-06	ECO_000398 adding second grounding tape on drawing	

## 2. CONTENTS

1.	REVISION RECORD .....	3
2.	CONTENTS .....	4
3.	MODULE CLASSIFICATION INFORMATION .....	5
4.	ASSEMBLY .....	6
4.1	Mounting Frame .....	6
5.	MODULE DRAWING .....	7
6.	ABSOLUTE MAXIMUM RATINGS .....	8
7.	ELECTRICAL CHARACTERISTICS .....	8
8.	BACKLIGHT ELECTRICAL CHARACTERISTICS .....	9
9.	ELECTRO-OPTICAL CHARACTERISTICS .....	9
10.	INTERFACES DESCRIPTION .....	12
10.1	J1 connector .....	12
10.2	P3 connector .....	14
11.	DIAGRAM BLOCK .....	14
12.	TIMING CHARACTERISTICS .....	15
13.	INSPECTION .....	15
14.	RELIABILITY TEST .....	16
15.	LEGAL INFORMATION .....	17
16.	CONTACT .....	18

### 3. MODULE CLASSIFICATION INFORMATION

RV	T	156	H	K	D	F	W	N	00
1.	2.	3.	4.	5.	6.	7.	8.	9.	10.

NO.	PARAMETER	SYMBOL
1.	BRAND	RV - Riverdi
2.	PRODUCT TYPE	T - TFT Standard
3.	DISPLAY SIZE	156 - 15.6"
4.	MODEL SERIAL NO.	H - High Brightness, IPS
5.	RESOLUTION	K - 1920 x 1080 px
6.	INTERFACE	D - MIPI DSI
7.	FRAME	F - With Mounting Metal Frame
8.	BACKLIGHT TYPE	W - LED White
9.	TOUCH PANEL	N - Without Capacitive Touch Panel
10.	VERSION	00 - version

## 4. ASSEMBLY

### 4.1 Mounting Frame

For dimensions 3.5", 4.3", 5.0", 7.0", 10.1", 12.1" and 15.6", the product with mounting frame version is available. Thanks to the four catches attached to the side, frame provides strong assembly to the surface by mounting element (like the screw, see Figure 1). The frames are specially designed to fit Riverdi products perfectly. The diameter of the mounting hole is 3.5mm.

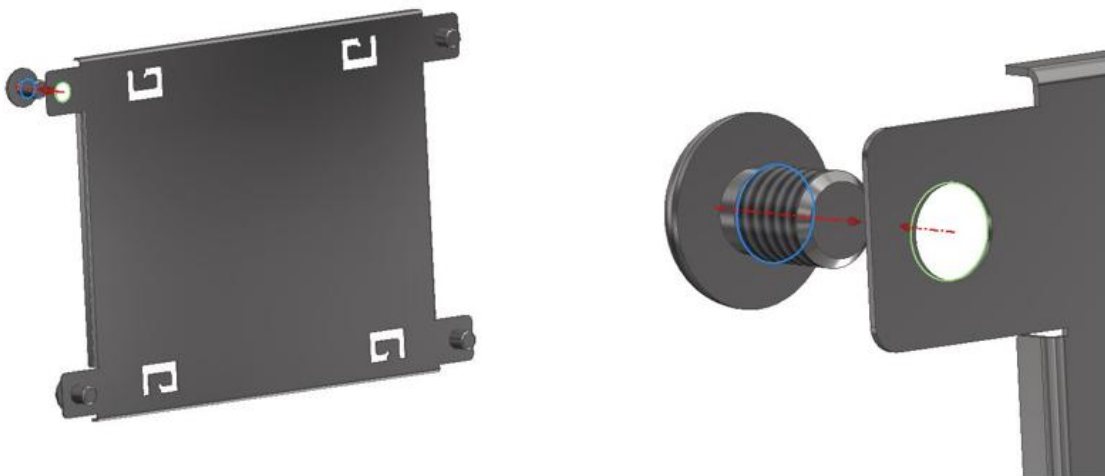

*Figure 1. Mounting Frame*

Revision:	Changes:	Date:
1.0	Initial Case	2025.06.27
1.1	Changed PCBA position	2025.09.15
1.2	PCBA Position & Tolerance Update	2026.02.02
1.3	ECO_000398, Addition Of Second Grounding Tape	2026.05.06

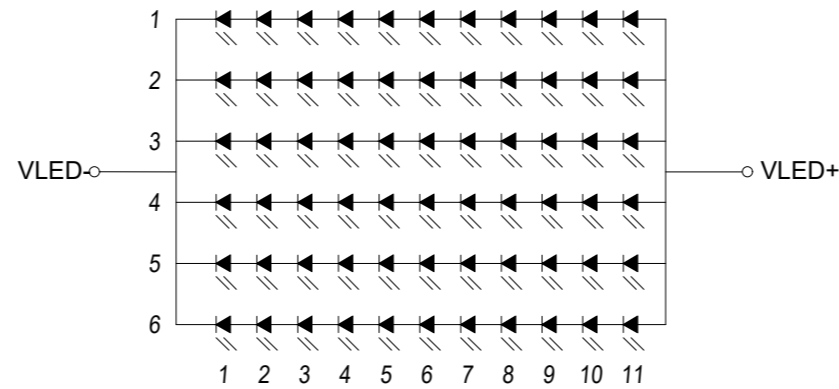
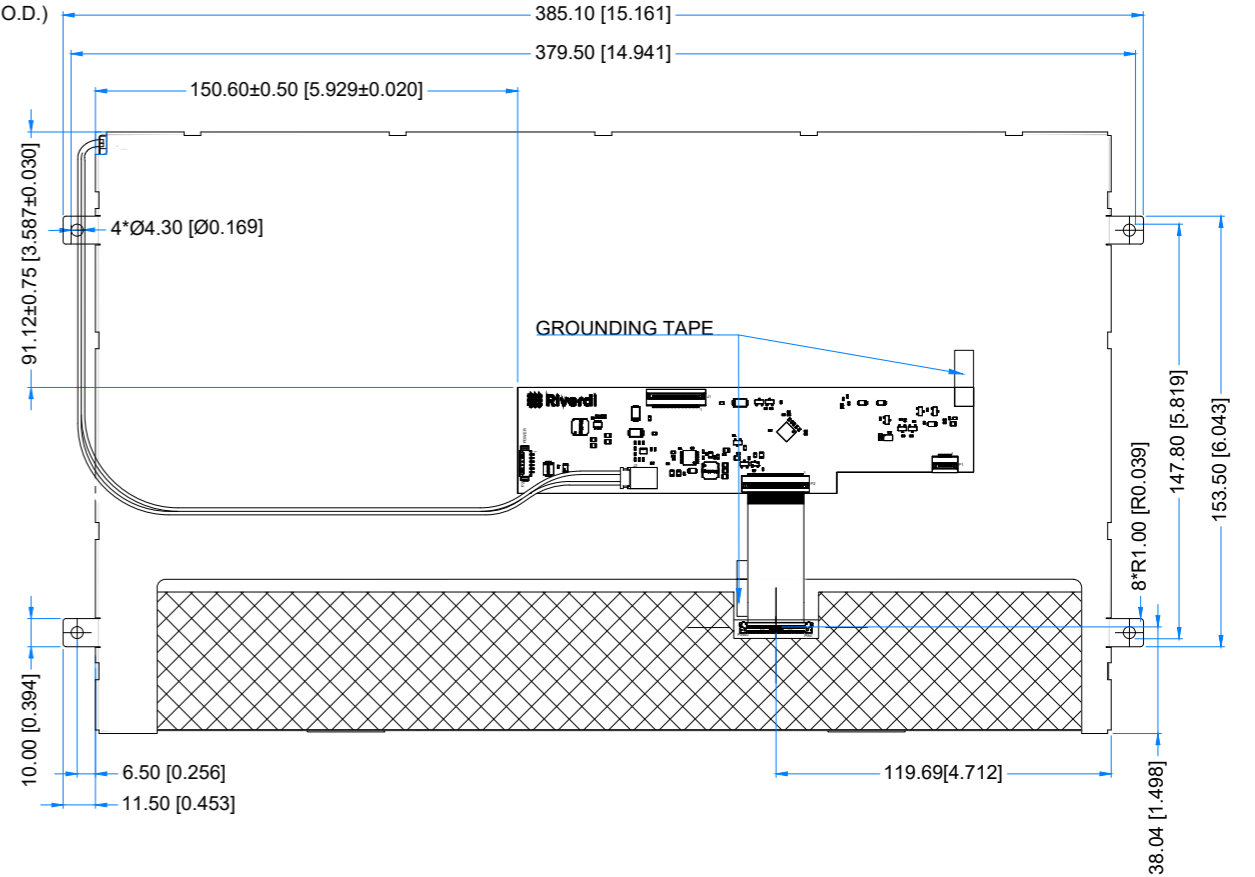
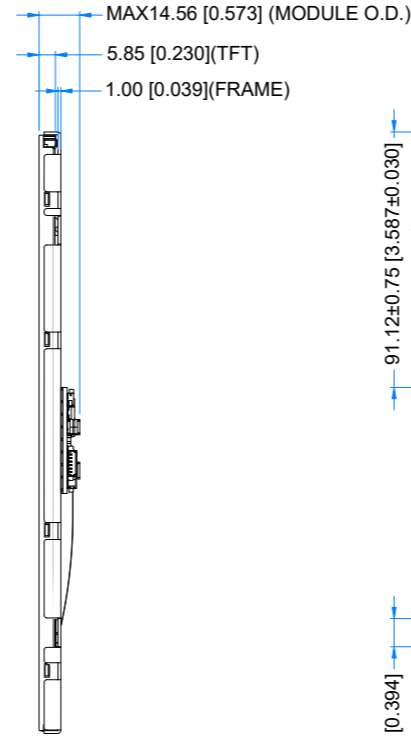
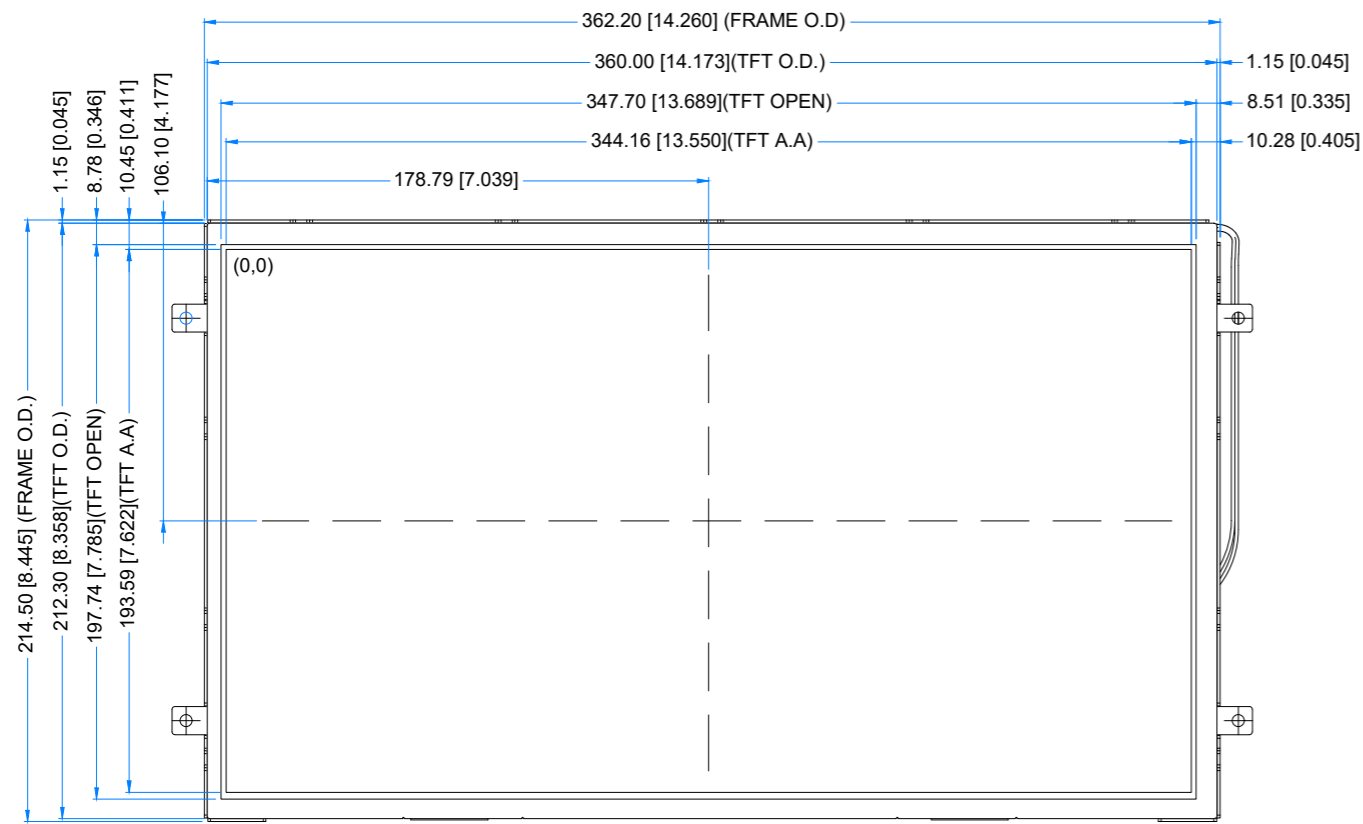

LED Diagram Circuit

**TFT NOTES:**  
1. DISPLAY TYPE: TRANSMISSIVE, NORMALLY BLACK  
2. RESOLUTION: 1920 x 1080  
3. VIEWING ANGLE: FREE  
4. DRIVING IC ON THE BOARD: SN65DSI84ZXHR  
5. INTERFACE: MIPI DSI  
6. SUPPLY VOLTAGE FOR MODULE: 6.0V-18.0V

**GENERAL NOTES:**  
1. MODULE SURFACE LUMINANCE: 1000 cd/m<sup>2</sup>  
2. OPERATING TEMPERATURE: -20°C ~ 70°C  
3. STORAGE TEMPERATURE: -30°C ~ 80°C  
4. WITHOUT INDIVIDUAL TOLERANCE: ±0.3mm  
5. RoHS COMPLIANT

PN: RVT156HKDFWN00

SN:

DRAWN: M.Stabinski

2026.05.06

1:2.70

CHECKED: M.Wierzbowski

2026.05.06

[mm]

APPR: M.Wierzbowski

2026.05.06

ISO A3

P. 1 of 1

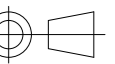

## 6. ABSOLUTE MAXIMUM RATINGS

PARAMETER	SYMBOL	MIN	MAX	UNIT
Supply Voltage for Module	$V_{DD}$	-0.5	18.0	V
Reference Voltage	$V_{REF}$	0	4.6	V
PWM Input Voltage	$V_{PWM}$	-0.3	7.4	V
Operating Temperature	$T_{OP}$	-20	70	°C
Storage Temperature	$T_{ST}$	-30	80	°C

**Note.** The above are maximum values. If exceeded, they may cause permanent damage to the unit.

## 7. ELECTRICAL CHARACTERISTICS

PARAMETER	SYMBOL	MIN	TYP	MAX	UNIT	NOTE	
Power Supply Voltage	$V_{DD}$	6.0	12.0	18.0	V	Note 1	
Reference Voltage	$V_{REF}$	0	-	3.6	V	Note 2	
Current drawn from $V_{REF}$	$I_{VREF}$	-	1.5	-	uA	$V_{REF}=1.8V$	
Input High Voltage	$V_{IH}$	$0.7V_{REF}$	-	-	V		
Input Low Voltage	$V_{IL}$	0	-	$0.3V_{REF}$	V		
PWM Logic Input Voltage	High Voltage	$V_{IH}$	1.2	-	$V_{DD}$	V	Note 3
	Low Voltage	$V_{IL}$	0	-	0.4	V	
PWM Frequency	$F_{PWM}$	200	-	1000	Hz		

**Note 1.** It is necessary to provide external power supply - molex connector signed "power". Power consumption of the module is about 15W, please make sure to provide proper parameters. Recommended 12V/2A.

**Note 2.** TYP reference voltage is 1.8V or 3.3V which is dependent on the SBC.

**Note 3.** PWM input is independent of  $V_{REF}$ . Min of logic high level is 1.2V and max logic low level is 0.4V.

Current drawn with 100% BL is 297mA/31V

Test condition: Ambient temperature 25°C

## 8. BACKLIGHT ELECTRICAL CHARACTERISTICS

PARAMETER	SYMBOL	MIN	TYP	MAX	UNIT	NOTE
Lifetime	-	-	50,000	-	hours	Note 1

**Note 1.** If LED is driven by high current, high ambient temperature and humidity condition, the lifetime of LED will be reduced. Operating life means brightness goes down to 50% initial brightness. Typical operating lifetime is estimated data.

## 9. ELECTRO-OPTICAL CHARACTERISTICS

ITEM	SYMBOL	CONDITION	MIN	TYP	MAX	UNIT	RMK	NOTE
Response Time	Tr+Tf	$\theta=0^\circ$ $\phi=0^\circ$ Ta=25 °C	-	25	30	ms	FIG 2.	4, 7
Contrast Ratio	Cr		800	1000	-	---	FIG 3.	1, 7
Surface Luminance	Lv		-	1000	-	cd/m <sup>2</sup>		2, 7
Viewing Angle Range	$\theta$	$\phi = 90^\circ$ $\phi = 270^\circ$ $\phi = 0^\circ$ $\phi = 180^\circ$	80	85	-	deg	FIG 4.	6
			80	85	-	deg		
			80	85	-	deg		
			80	85	-	deg		
CIE (x, y) Chromaticity	Rx	$\theta=0^\circ$ $\phi=0^\circ$ Ta=25 °C	0.562	0.602	0.642	-	FIG 3.	5,7
	Ry		0.299	0.339	0.379	-		
	Gx		0.302	0.342	0.382	-		
	Gy		0.531	0.571	0.611	-		
	Bx		0.075	0.115	0.155	-		
	By		0.103	0.143	0.183	-		
	Wx		0.274	0.314	0.354	-		
	Wy		0.319	0.359	0.399	-		

**Note 1.** Contrast Ratio (CR) is defined mathematically as below, for more information see Figure 2.

$$\text{Contrast Ratio} = \frac{\text{Average Surface Luminance with all white pixels (P1, P2, P3, P4, P5)}}{\text{Average Surface Luminance with all black pixels (P1, P2, P3, P4, P5)}}$$

**Note 2.** Surface luminance is the LCD surface from the surface with all pixels displaying white. For more information see Figure 2.

$$L_v = \text{Average Surface Luminance with all white pixels (P1, P2, P3, P4, P5)}$$

**Note 3.** The uniformity in surface luminance  $\delta$  WHITE is determined by measuring luminance at each test position 1 through 5 and then dividing the minimum luminance of 5 points luminance by maximum luminance of 5 points luminance. For more information see Figure 2.

$$\delta \text{ WHITE} = \frac{\text{Minimum Surface Luminance with all white pixels (P1, P2, P3, P4, P5)}}{\text{Maximum Surface Luminance with all white pixels (P1, P2, P3, P4, P5)}}$$

**Note 4.** Response time is the time required for the display to transition from white to black (Rise Time,  $T_r$ ) and from black to white (Decay Time,  $T_f$ ). For additional information see Figure 1. The test equipment is BM-7A.

**Note 5.** CIE (x, y) chromaticity, the x, y value is determined by measuring luminance at each test position 1 through 5, and then make average value.

**Note 6.** For TFT module, viewing angle is the angle at which the contrast ratio is greater 10. The angles are determined for the horizontal or x axis and the vertical or y axis with respect to the z axis which is normal to LCD surface. For more information see Figure 3.

**Note 7.** Viewing angle is measured at the center point of the LCD by CONOSCOPE (ergo-80). For response time testing, the testing data is based on BM-7A. Instruments for Contrast Ratio, Surface Luminance, Luminance Uniformity, Chromaticity the test data is based on SR-3A.

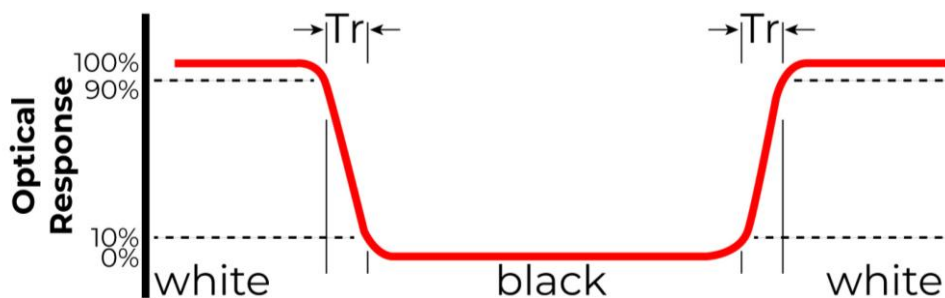

*Figure 2. The definition of response time*

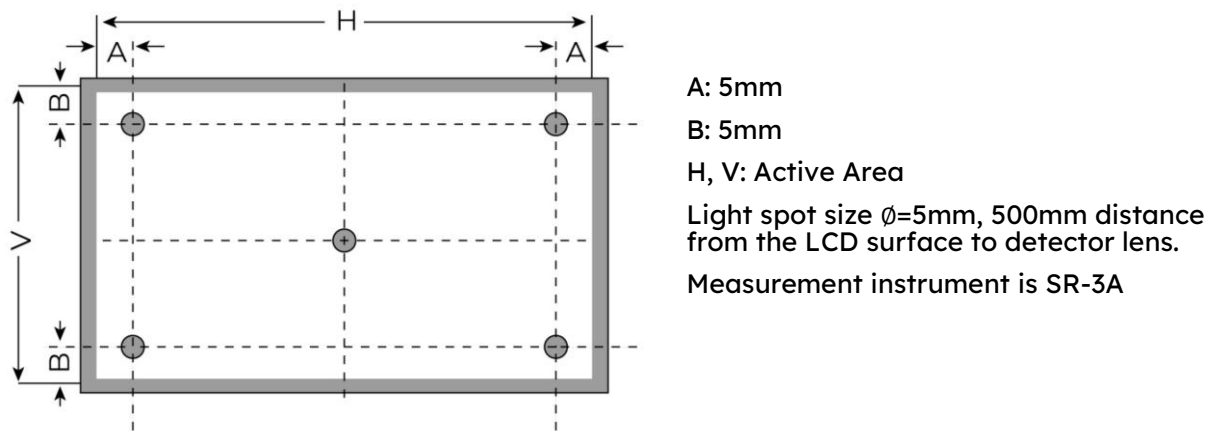

Figure 3. Measuring method for Contrast ratio, surface luminance, Luminance uniformity, CIE (x, y) chromaticity

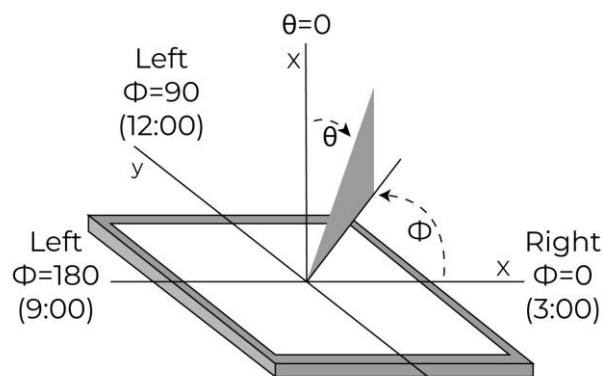

Figure 4. The definition of viewing angle

## 10. INTERFACES DESCRIPTION

### 10.1 J1 connector

PIN	SYMBOL	I/O	DESCRIPTION	NOTE
1	GND	P	Ground	
2	DSI_D0P	I/O	MIPI DSI differential data pair. (Data lane 0)	
3	DSI_D0N	I/O	MIPI DSI differential data pair. (Data lane 0)	
4	GND	P	Ground	
5	DSI_D1P	I	MIPI DSI differential data pair. (Data lane 1)	
6	DSI_D1N	I	MIPI DSI differential data pair. (Data lane 1)	
7	GND	P	Ground	
8	DSI_CLKP	I	MIPI DSI differential clock pair.	
9	DSI_CLKN	I	MIPI DSI differential clock pair.	
10	GND	P	Ground	
11	DSI_D2P	I	MIPI DSI differential data pair. (Data lane 2)	
12	DSI_D2N	I	MIPI DSI differential data pair. (Data lane 2)	
13	GND	P	Ground	
14	DSI_D3P	I	MIPI DSI differential data pair. (Data lane 3)	
15	DSI_D3N	I	MIPI DSI differential data pair. (Data lane 3)	
16	GND	P	Ground	
17	PWR_DN	I	Power down (With locally generated reset after releasing power-down) Active Low, display is off when signal is low;	
18	PWM	I	Backlight brightness control	
19	INT	O	Touch panel Interrupt signal; Open-drain output, active low	

20	I2C_SCL	I	I2C clock signal	
21	I2C_SDA	I/O	I2C data signal	
22	RESET	I	Touch panel reset	
23	NC	-	No connection	
24	V <sub>REF</sub>	P	Reference voltage	
25	NC	-	No connection	
26	5.0V	P	Power supply V <sub>DD</sub>	
27		P		
28		P		
29		P		
30	GND	P	Ground	
31	NC	-	No connection	
32	NC	-	No connection	
33	NC	-	No connection	
34	NC	-	No connection	

**Note 1.** Matched 34 pins, 0.5 mm pitch, 150mm long FFC accessory: FFC0534150.

**Note 2.** Internally pull-up with 15K resistor to V<sub>REF</sub>.

**Note 3.** Backlight driver is TPS61500. PWM frequency range: 200Hz-1KHz.

0% PWM duty cycle corresponds to minimum brightness.

100% PWM duty cycle corresponds to maximum brightness.

## 10.2 P3 connector

PIN	SYMBOL	DESCRIPTION
1	VSUPPLY	Power supply, 6.0-18.0V
2	VSUPPLY	Power supply, 6.0-18.0V
3	VSUPPLY	Power supply, 6.0-18.0V
4	VSUPPLY	Power supply, 6.0-18.0V
5	GND	Ground
6	GND	Ground

**Note.** Matched Riverdi power supply cable: RVA-0106M-1.25FF-1

## 11. DIAGRAM BLOCK

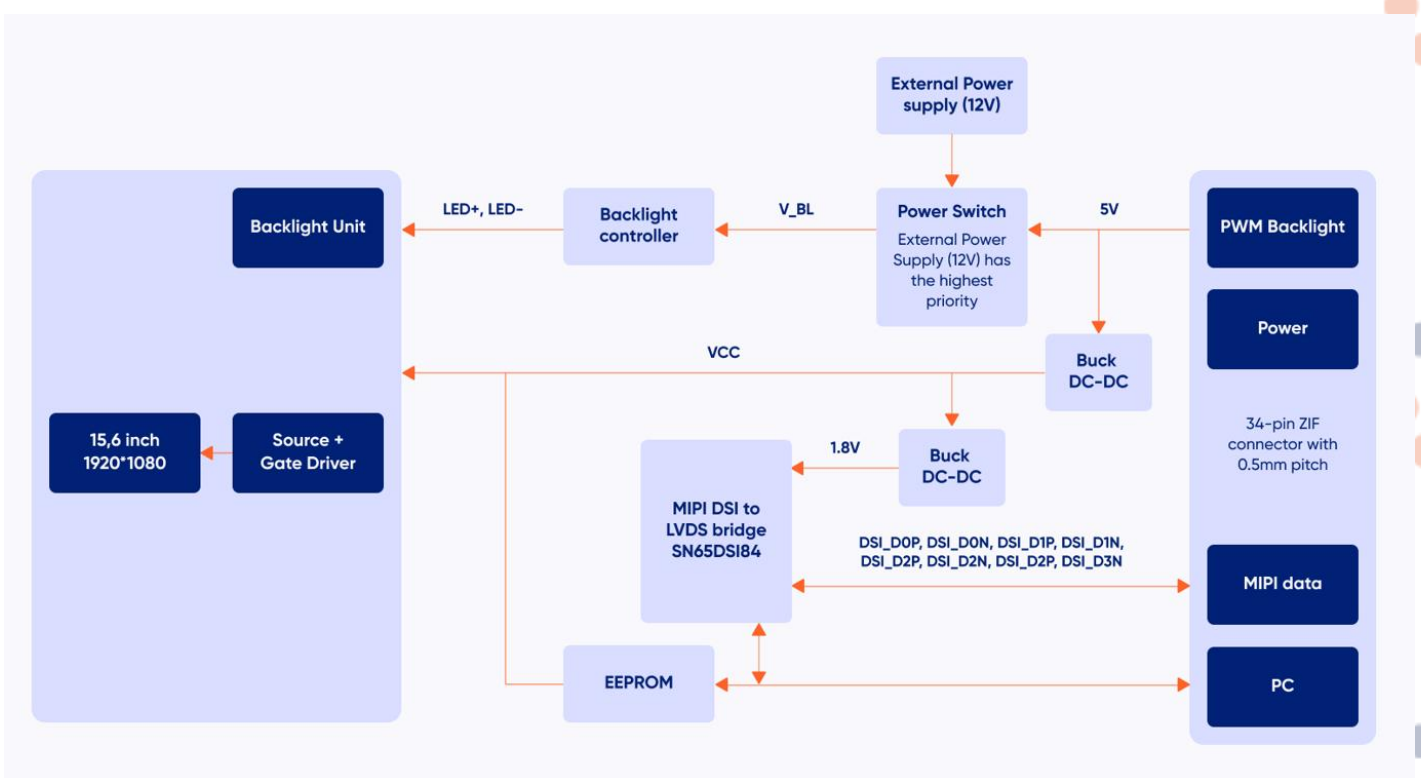

## 12. TIMING CHARACTERISTICS

The TFT of the module applies Riverdi high brightness, IPS, 15.6" TFT: RVT156HKLFWCA0-B

For detailed information of the display, please refer to datasheet of display.

## 13. INSPECTION

Standard acceptance/rejection criteria for TFT module according to document available [here](#).

## 14. RELIABILITY TEST

NO.	TEST ITEM	TEST CONDITION	NOTE
1	High Temperature Storage	80°C/120 hours	Note 1
2	Low Temperature Storage	-30°C/120 hours	
3	High Temperature Operating	70°C/120 hours	
4	Low Temperature Operating	-20°C/120 hours	
5	High Temperature and High Humidity	40°C, 90%RH, 120Hrs	
7	Thermal Cycling Test (No operation)	-20°C for 30min, 70°C for 30 min. 100 cycles. Then test at room temperature after 1 hour	Note 2
8	Vibration Test	Frequency: 10 ÷ 55 Hz. Stroke: 1.5 mm. Sweep: 10Hz ÷ 55Hz ÷ 10 Hz. 2 hours for each direction of X, Y, Z (Total 6 hours)	
9	Package Drop Test	Height: 60 cm 1 corner, 3 edges, 6 surfaces	

**Note 1.** Sample quantity for each test item is 5 ÷ 10 pcs.

**Note 2.** The device is kept at room temperature for 2 hours prior to starting the test

## 15. LEGAL INFORMATION

CE marking is usually obligatory only for a complete end product. Riverdi display modules are semi-finished goods which are used as inputs to become part of the finished products.

Therefore, Riverdi display modules are not CE marked.

This is not a standalone product. It was designed as an electronic component. It needs integration with a whole system to be fully functional.

Riverdi grants the guarantee for the proper operation of the goods for a period of 12 months from the date of possession of the goods. If in a consequence of this guaranteed execution the customer has received the defects-free item as replacement for the defective item, the effectiveness period of this guarantee shall start anew from the moment the customer receives the defects-free item.

Information about device is the property of Riverdi and may be the subject of patents pending or granted. It is not allowed to copy or disclosed this document without prior written permission.

Riverdi endeavors to ensure that all contained information in this document is correct but does not accept liability for any error or omission. Riverdi products are in developing process and published information may be not up to date. Riverdi reserves the right to update and makes changes to Specifications or written material without prior notice at any time. It is important to check the current position with Riverdi.

Images and graphics used in this document are only for illustrative the purpose. All images and graphics are possible to be displayed on the range products of Riverdi, however the quality may vary. Riverdi is no liable to the buyer or to any third party for any indirect, incidental, special, consequential, punitive, or exemplary damages (including without limitation lost profits, lost savings, or loss of business opportunity) relating to any product, service provided or to be provided by Riverdi, or the use or inability to use the same, even if Riverdi has been advised of the possibility of such damages.

Riverdi products are not fault tolerant nor designed, manufactured or intended for use or resale as on line control equipment in hazardous environments requiring fail-safe performance, such as in the operation of nuclear facilities, aircraft navigation or communication systems, air traffic control, direct life support machines or weapons systems in which the failure of the product could lead directly to death, personal injury or severe physical or environmental damage ('High-Risk Activities'). Riverdi and its suppliers specifically disclaim any expressed or implied warranty of fitness for High-Risk Activities. Using Riverdi products and devices in 'High-Risk Activities' and in any other application is entirely at the buyer's risk, and the buyer agrees to defend, indemnify and hold harmless Riverdi from all damages, claims or expenses resulting from such use. No licenses are conveyed, implicitly or otherwise, under any Riverdi intellectual property rights.

## 16. CONTACT

### Your Success is Our Priority

Stuck on a technical challenge? Need expert guidance?  
Our dedicated support team is just a message away.

Contact us at

[contact@riverdi.com](mailto:contact@riverdi.com)

We're here to ensure your project's success, every step of the way!