



TFT MODULE SPECIFICATION

RVT156HKLNWCA0-B

EVE5 IPS 15.6" FULL HD LCD TFT display datasheet

Rev. 1.2

2026-05-14

Riverdi Sp. z o.o.

Nowy Swiat 36
80-299 Gdansk, Poland
VAT ID: PL5842767153

Registration number (KRS): 0000923967

+48 587 703 116

Office hours: 9:00 to 17:30 CET (Mon-Fri)

contact@riverdi.com

riverdi.com



ITEM	CONTENTS	UNIT
LCD Type	TFT/Transmissive/Normally Black/IPS	/
Size	15.6	Inch
Viewing Direction	All	/
Outside Dimensions (W x H x D)	360.00 x 212.40 x 22.86	mm
Active Area (W x H)	345.76 x 195.19	mm
Pixel Pitch (W x H)	0.1793 x 0.1793	mm
Resolution	1920 x 1080	/
Brightness	850	cd/m ²
Color Depth	16.7 M	/
Pixel Arrangement	RGB Vertical Stripe	/
Driver IC of Board	BT820B	/
Interface	SPI/QSPI	/
Host Connector	RiBUS, ZIF 20 pin, 0.5mm pitch, down-side contact	/
With/Without Touch	With Projected Capacitive Touch Panel	/
CTP Driver	ILI2510	/
Supply Voltage for Module	6.0	V
Bonding Technology	Optical Bonding	/
Weight	1143	g

Note 1. RoHS3 compliant

Note 2. LCM weight tolerance: $\pm 5\%$.

1. REVISION RECORD

REV NO.	REV DATE	CONTENTS	REMARKS
1.0	2025-07-04	Initial release	
1.1	2026-01-19	PCBA position update	
1.2	2026-05-14	Drawing update, details described in drawing revision.	

2. CONTENTS

1.	REVISION RECORD	3
2.	CONTENTS	4
3.	MODULE CLASSIFICATION INFORMATION	5
4.	MODULE DRAWING	6
5.	ABSOLUTE MAXIMUM RATINGS	7
6.	ELECTRICAL CHARACTERISTICS	7
7.	BACKLIGHT ELECTRICAL CHARACTERISTICS	8
8.	ELECTRO-OPTICAL CHARACTERISTICS	9
9.	INTERFACES DESCRIPTION	12
9.1	P3 connector - RiBUS description	12
9.2	Audio Jack - CN4	13
10.	BT820B CONTROLLER SPECIFICATION	13
10.1	Serial host interface	14
10.2	BLOCK DIAGRAMS	14
10.3	Host Interface SPI mode 0	16
10.4	Backlight driver block diagram	17
11.	1024Mb NOR FLASH MEMORY	17
12.	TFT TIMING CHARACTERISTICS	17
13.	CAPACITIVE TOUCH SCREEN PANEL SPECIFICATIONS	18
13.1	Mechanical characteristics	18
13.2	Electrical characteristics	18
14.	INSPECTION	19
15.	RELIABILITY TEST	19
16.	LEGAL INFORMATION	20
17.	CONTACT	21

3. MODULE CLASSIFICATION INFORMATION

RV	T	156	H	K	B	N	W	C	A0	B
1.	2.	3.	4.	5.	6.	7.	8.	9.	10.	11.

NO.	PARAMETER	SYMBOL
1.	BRAND	RV - Riverdi
2.	PRODUCT TYPE	T - TFT Standard
3.	DISPLAY SIZE	156 - 15.6"
4.	MODEL SERIAL NO.	H - High Brightness, IPS
5.	RESOLUTION	K - 1920 x 1080 px
6.	INTERFACE	B - SPI/QSPI
7.	FRAME	N - Without Mounting Metal Frame
8.	BACKLIGHT TYPE	W - LED White
9.	TOUCH PANEL	C - With Capacitive Touch Panel
10.	VERSION	A0 - version
11.	BONDING TECHNOLOGY	B - Optical bonding

Revision:	Changes:	Date:
1.0	Initial Case	2025.07.04
1.1	Changed Position Of PCBA	2026.01.19
1.2	Deleted Sensor Dim, Updated Front View, Addition Of Cover Glass Detailed View	2026.05.14

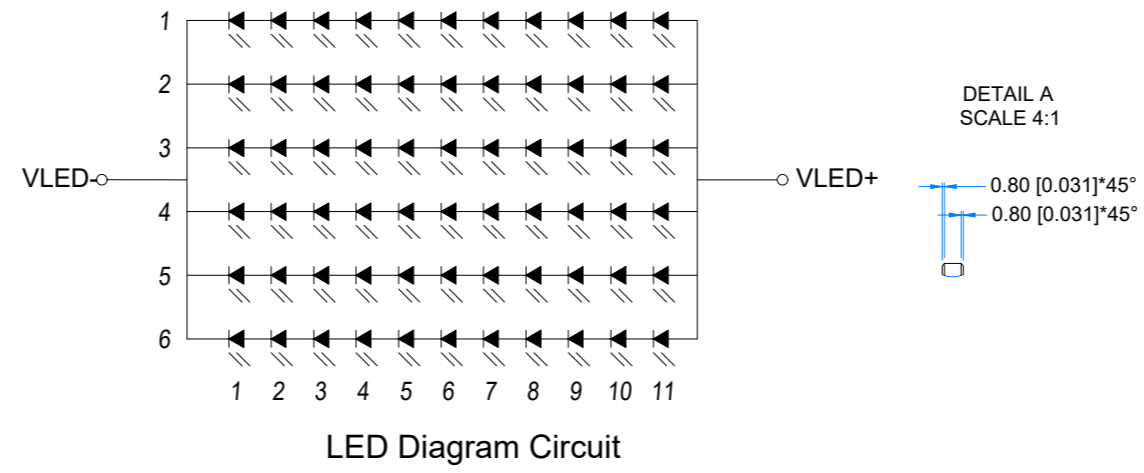
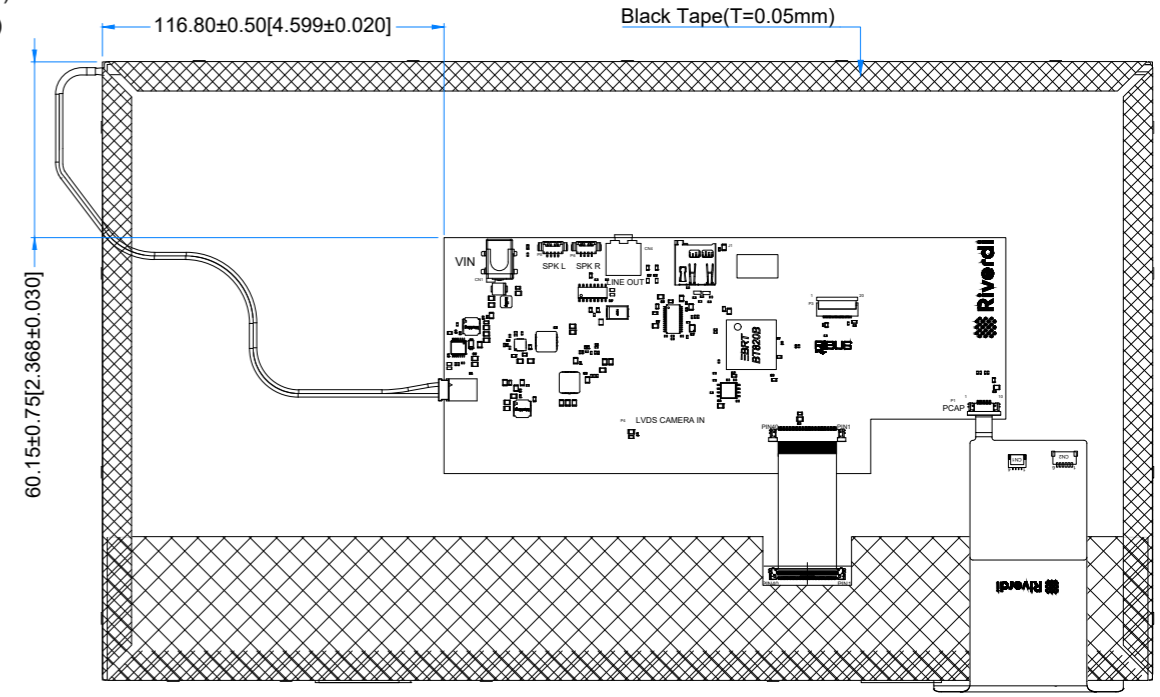
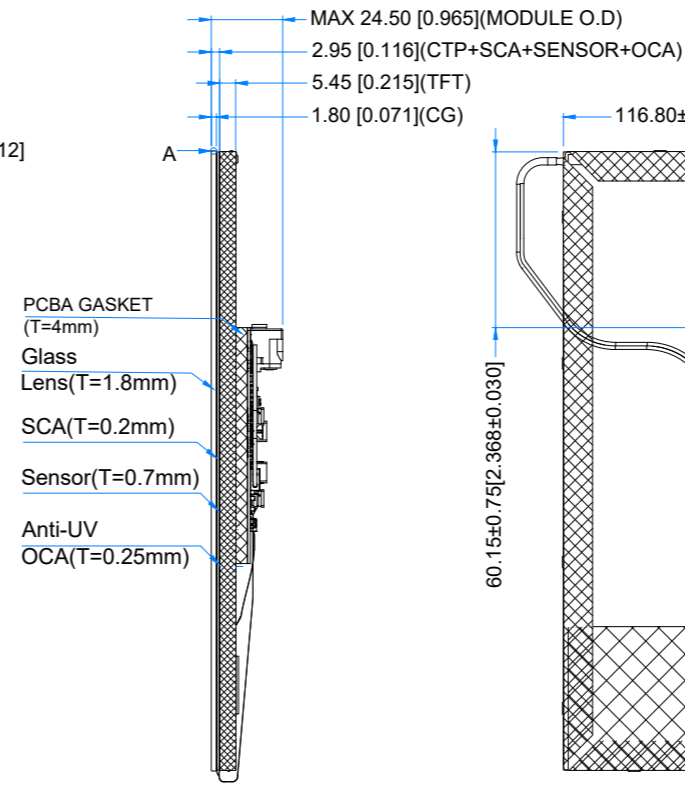
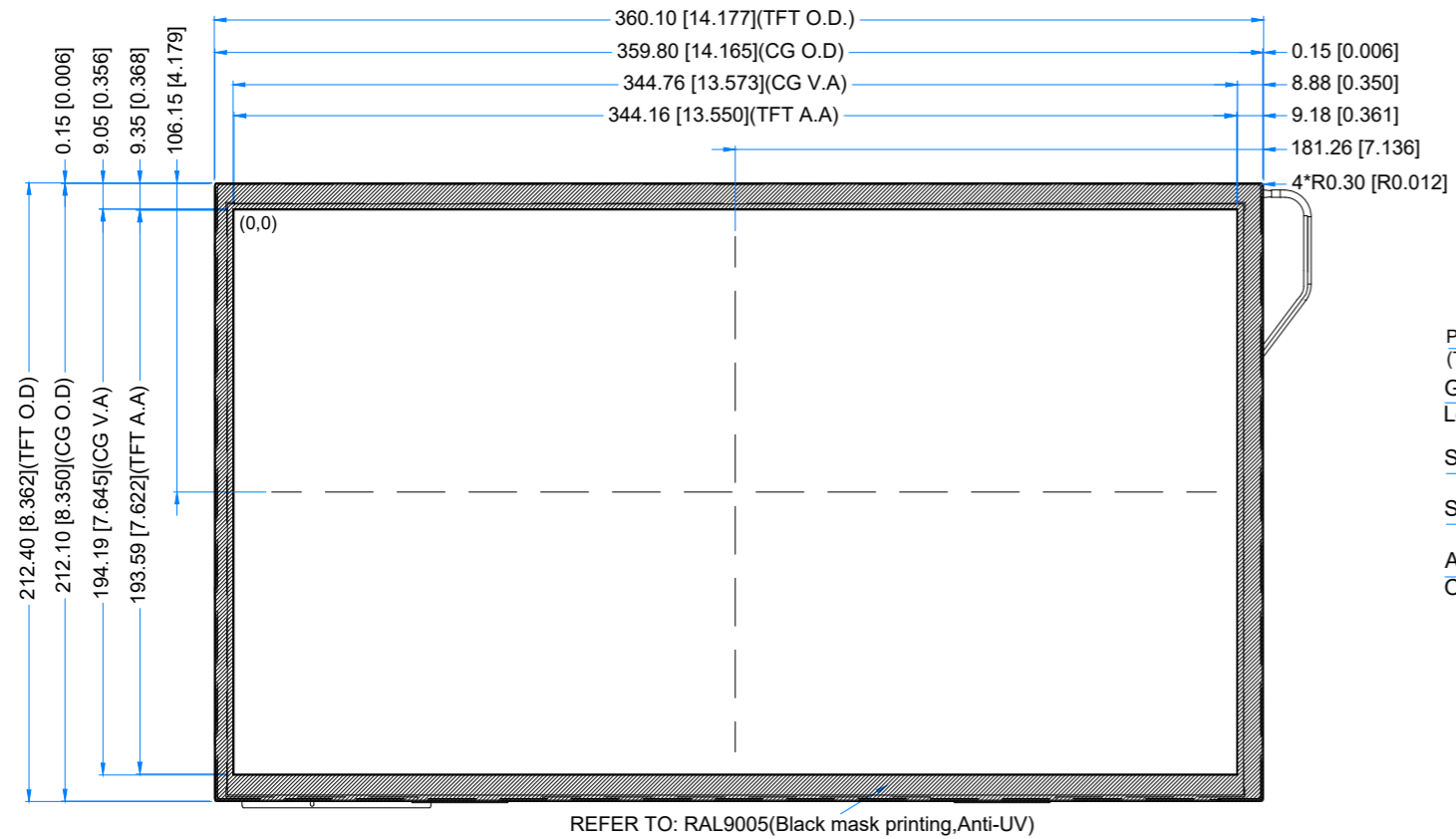

TFT NOTES:

- LCD TYPE: TRANSMISSIVE, NORMALLY BLACK, IPS
- RESOLUTION: 1920 x 1080
- VIEWING ANGLE: FREE
- DRIVING IC ON THE BOARD: BT820B
- INTERFACE: SPI/QSPI
- DRIVING VOLTAGE: 6.0V

TP NOTES:

- TP STRUCTURE: G+G
- CG THICKNESS: 1.8mm
- DRIVER IC: ILI2510
- INTERFACE: I2C, USB
- OPERATING VOLTAGE: 3.3V(CTP_I2C); 5.0V (CTP_USB)

GENERAL NOTES:

- MODULE SURFACE LUMINANCE: 850 cd/m²
- OPTICAL BONDING
- OPERATING TEMPERATURE: -20°C ~ 70°C
- STORAGE TEMPERATURE: -30°C ~ 80°C
- WITHOUT INDIVIDUAL TOLERANCE: ±0.3mm
- RoHS COMPLIANT

PN: RVT156HKBNWCA0-B

SN:

DRAWN: M.Stabinski

CHECKED: M.Wierzbowski

APPR: M.Wierzbowski

2026.05.14	1:2.59	
2026.05.14	[mm]	
2026.05.14	ISO A3	

P. 1 of 1

5. ABSOLUTE MAXIMUM RATINGS

PARAMETER	SYMBOL	MIN	MAX	UNIT
Supply Voltage for Module	V_{DD}	-0.5	18.0	V
Operating Temperature	T_{OP}	-20	70	°C
Storage Temperature	T_{ST}	-30	80	°C

Note. The above are maximum values. If exceeded, they may cause permanent damage to the unit.

6. ELECTRICAL CHARACTERISTICS

PARAMETER	SYMBOL	MIN	TYP	MAX	UNIT
Power Supply Voltage	V_{CC}	6.0	12.0	17.0	V
Logic Input Voltage	V_{IH}	$0.7V_{CC}$	-	V_{CC}	V
	V_{IL}	0	-	$0.3V_{CC}$	V

PARAMETER	SYMBOL	MIN	TYP	MAX	UNIT
Current drawn from module $V_{DD}@6.0V$	I_{VDD}	-	2520	-	mA
Current drawn from module $V_{DD}@12.0V$	I_{VDD}	-	1110	-	mA
Current drawn from module $V_{DD}@17.0V$	I_{VDD}	-	778	-	mA

Note 1. Animated pictures are displayed on the screen and there is no QSPI communication during the measurement of TYP and MAX values.

TYP value is measured when the audio is off.

MAX value is measured when the audio is on, and volume is set to maximum.

Riverdi loudspeaker RVA-SPK1.5W-C150 is applied during the measurement.

7. BACKLIGHT ELECTRICAL CHARACTERISTICS

PARAMETER	SYMBOL	MIN	TYP	MAX	UNIT	NOTE
Lifetime	-	-	50,000	-	Hours	Note 1

Note 1. Operating lifetime means the period in which the LED brightness goes down to 50% of the initial brightness. Typical operating lifetime is the estimated parameter.

8. ELECTRO-OPTICAL CHARACTERISTICS

ITEM	SYMBOL	CONDITION	MIN	TYP	MAX	UNIT	RMK	NOTE
Response Time	Tr+Tf	$\theta=0^\circ$ $\phi=0^\circ$ Ta=25 °C	-	25	30	ms	FIG 1.	4, 7
Contrast Ratio	Cr		800	1000	-	---	FIG 2.	1, 7
Surface Luminance	Lv		-	850	-	cd/m ²		2, 7
Viewing Angle Range	θ	$\phi = 90^\circ$ $\phi = 270^\circ$ $\phi = 0^\circ$ $\phi = 180^\circ$	80	85	-	deg	FIG 3.	6
			80	85	-	deg		
			80	85	-	deg		
			80	85	-	deg		
CIE (x, y) Chromaticity	Rx	$\theta=0^\circ$ $\phi=0^\circ$ Ta=25 °C	0.562	0.602	0.642	-	FIG 2.	5,7
	Ry		0.299	0.339	0.379	-		
	Gx		0.302	0.342	0.382	-		
	Gy		0.531	0.571	0.611	-		
	Bx		0.075	0.115	0.155	-		
	By		0.103	0.143	0.183	-		
	Wx		0.274	0.314	0.354	-		
	Wy		0.319	0.359	0.399	-		

Note 1. Contrast Ratio (CR) is defined mathematically as below, for more information see Figure 2.

$$\text{Contrast Ratio} = \frac{\text{Average Surface Luminance with all white pixels (P1, P2, P3, P4, P5)}}{\text{Average Surface Luminance with all black pixels (P1, P2, P3, P4, P5)}}$$

Note 2. Surface luminance is the LCD surface from the surface with all pixels displaying white. For more information see Figure 2.

$$L_v = \text{Average Surface Luminance with all white pixels (P1, P2, P3, P4, P5)}$$

Note 3. The uniformity in surface luminance δ WHITE is determined by measuring luminance at each test position 1 through 5 and then dividing the minimum luminance of 5 points luminance by maximum luminance of 5 points luminance. For more information see Figure 2.

$$\delta \text{ WHITE} = \frac{\text{Minimum Surface Luminance with all white pixels (P1, P2, P3, P4, P5)}}{\text{Maximum Surface Luminance with all white pixels (P1, P2, P3, P4, P5)}}$$

Note 4. Response time is the time required for the display to transition from white to black (Rise Time, Tr) and from black to white (Decay Time, Tf). For additional information see Figure 1. The test equipment is BM-7A.

Note 5. CIE (x, y) chromaticity, the x, y value is determined by measuring luminance at each test position 1 through 5, and then make average value.

Note 6. For TFT module, viewing angle is the angle at which the contrast ratio is greater 10. The angles are determined for the horizontal or x axis and the vertical or y axis with respect to the z axis which is normal to LCD surface. For more information see Figure 3.

Note 7. Viewing angle is measured at the center point of the LCD by CONOSCOPE (ergo-80). For response time testing, the testing data is based on BM-7A. Instruments for Contrast Ratio, Surface Luminance, Luminance Uniformity, Chromaticity the test data is based on SR-3A.

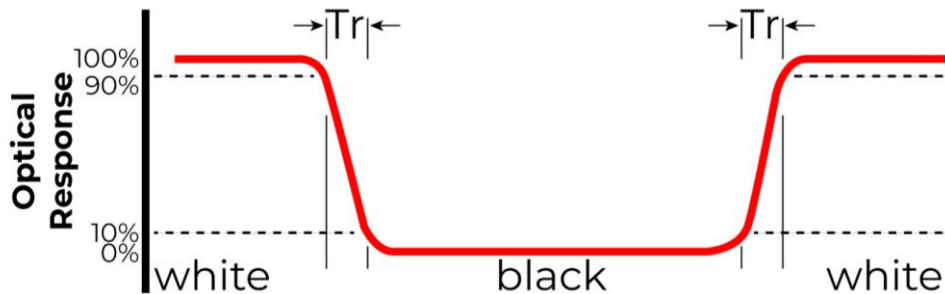

Figure 1. The definition of response time

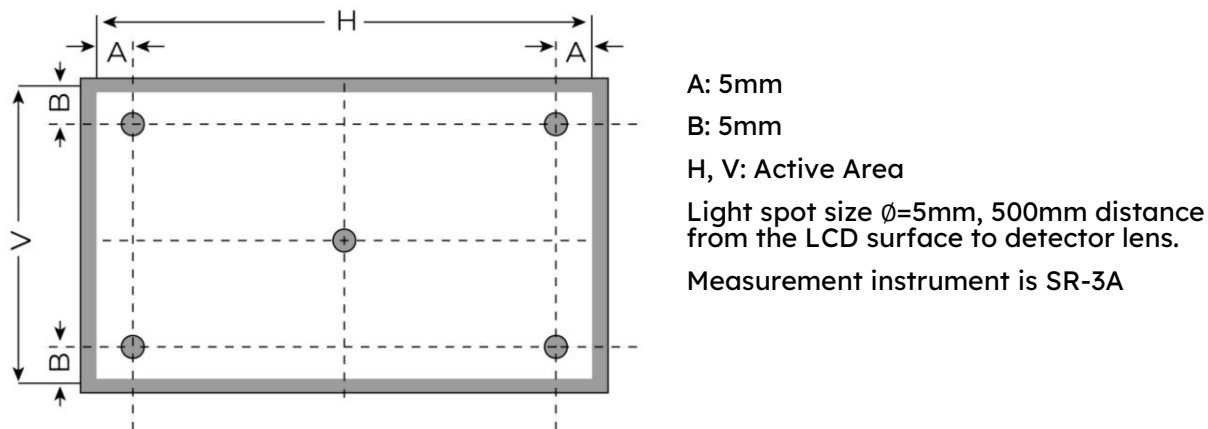

Figure 2. Measuring method for Contrast ratio, surface luminance, Luminance uniformity, CIE (x, y) chromaticity

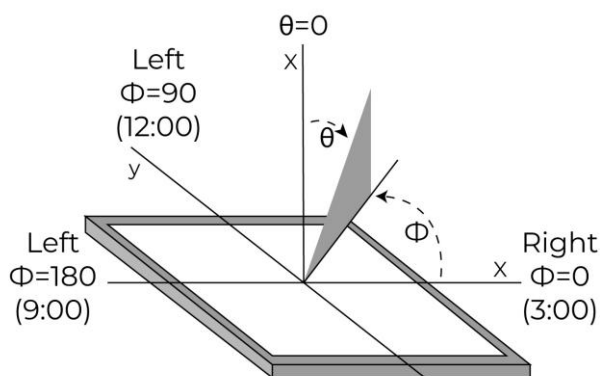

Figure 3. The definition of viewing angle

9. INTERFACES DESCRIPTION

9.1 P3 connector – RiBUS description

PIN	SYMBOL	DESCRIPTION
1	-	Reserved, keep floating
2	GND	Ground
3	SPI_SCLK	SPI SCK signal
4	MISO/ IO.1	SPI MISO signal / SPI Quad mode: SPI data line 1
5	MOSI/ IO.0	SPI MOSI signal / SPI Quad mode: SPI data line 0
6	CS	SPI chips select signal
7	INT	Interrupt signal from device to the system, Active Low, internally 47k Pull UP
8	RST/PD	Reset / Power down signal, Active Low, Internally Pulled UP 47k
9	GPIO.0	GPIO.0
10	DISP_AUDIO	Display audio in/out
11	GPIO.1/IO.2	SPI Single/Dual mode: General purpose IO0. QSPI mode: SPI data line 2
12	GPIO.2/IO.3	SPI Single/Dual mode: General purpose IO1. QSPI mode: SPI data line 3
13	NC	Not connected
14	NC	Not connected
15	NC	Not connected
16	NC	Not connected
17	-	Reserved, keep floating
18	-	Reserved, keep floating
19	BLGND	Backlight Ground, internally connected to GND
20	BLGND	Backlight Ground, internally connected to GND

9.2 Audio Jack – CN4

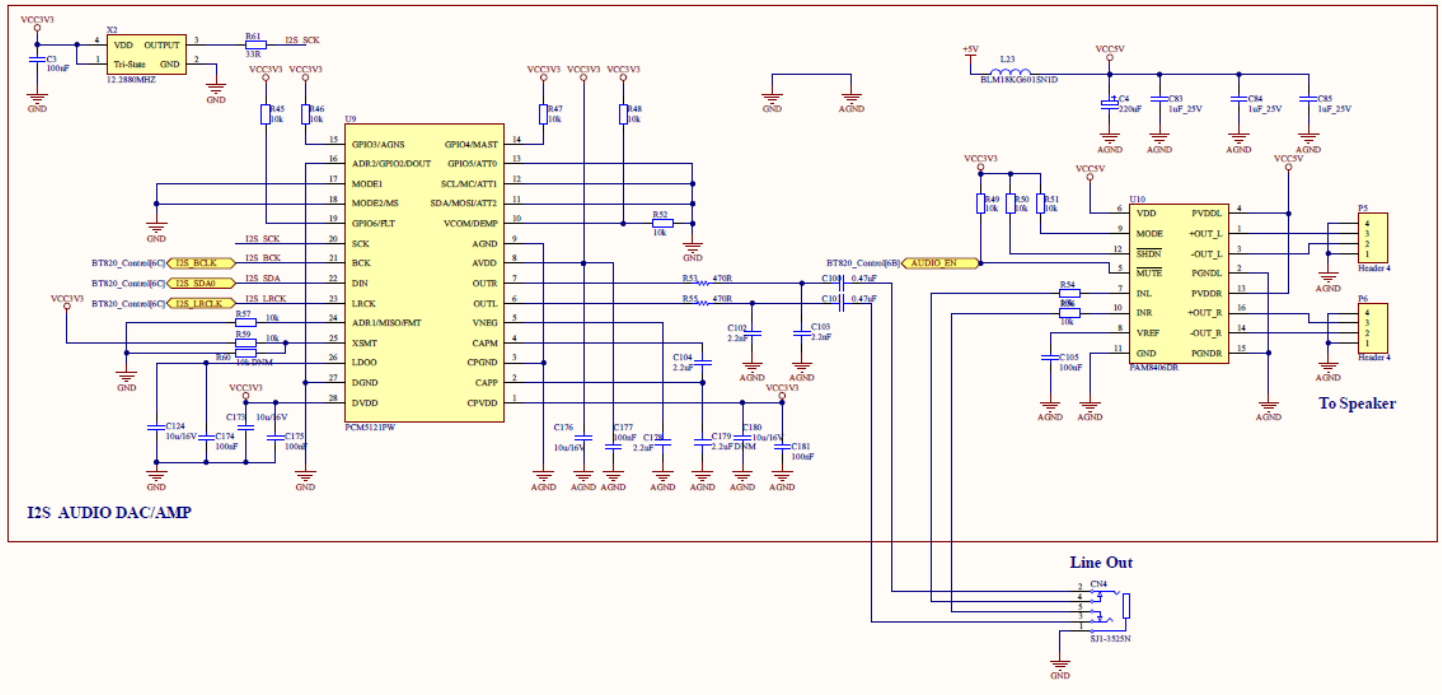

Figure 4. The simplified audio circuit design

10. BT820B CONTROLLER SPECIFICATION

BT820B or EVE5 (Embedded Video Engine 5) simplifies the system architecture for advanced human machine interfaces (HMIs) by providing functionality for display, audio, and touch as well as an object-oriented architecture approach that extends from display creation to the rendering of the graphics.

10.1 Serial host interface

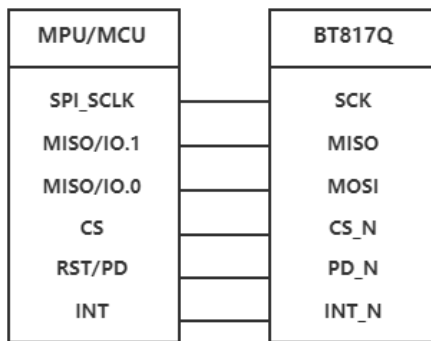

Figure 5. SPI single/dual interface connection

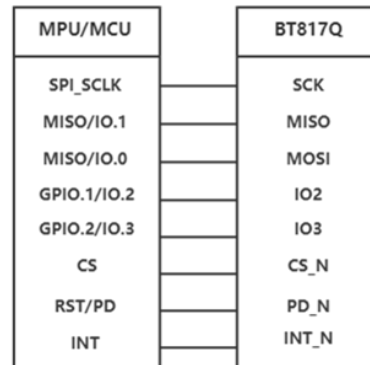

Figure 6. QSPI interface connection

SPI Interface - the SPI slave interface operates up to 30MHz.

Only SPI mode 0 is supported. The SPI interface is selected by default.

QSPI Interface - the QSPI slave interface operates up to 30MHz. Only SPI mode 0 is supported.

The QSPI can be configured as a SPI slave in SINGLE, DUAL or QUAD channel modes.

By default, the SPI slave operates in the SINGLE channel mode with MOSI as input from the master and MISO as output to the master. DUAL and QUAD channel modes can be configured through the SPI slave itself. To change the channel modes, write to register REG_SPI_WIDTH.

10.2 BLOCK DIAGRAMS

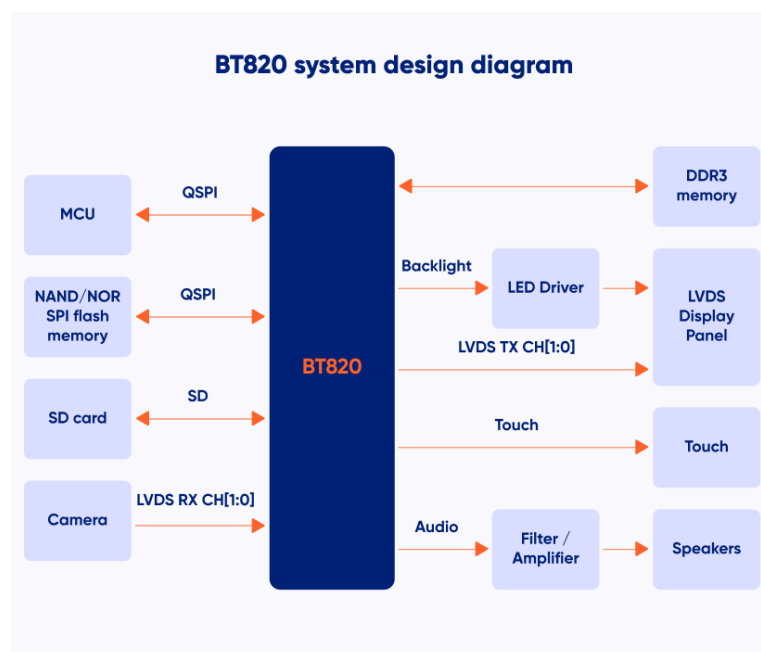

Figure 7. System design diagram.

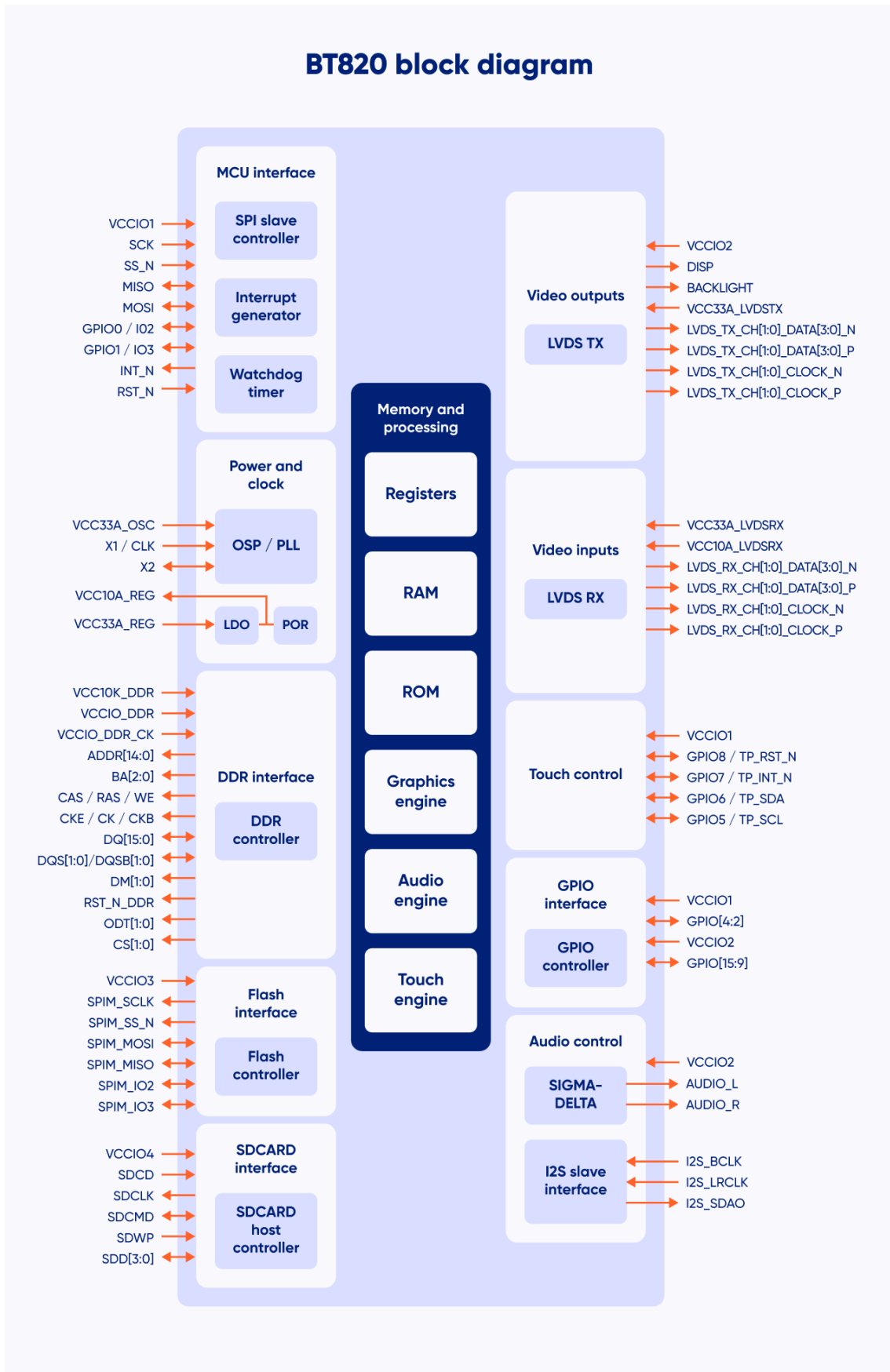

Figure 8. BT820 block diagram.

10.3 Host Interface SPI mode 0

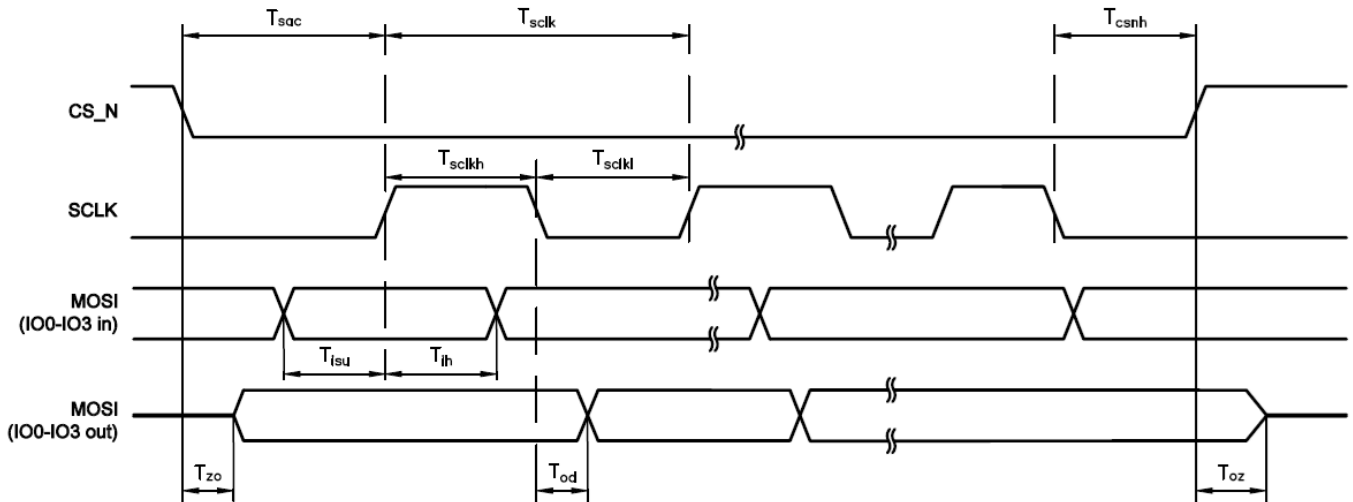

Figure 9. SPI timing diagram

PARAMETER	DESCRIPTION	VCCIO=1.8V		VCCIO=2.5V		VCCIO=3.3V		UNIT
		MIN	MAX	MIN	MAX	MIN	MAX	
T_{SCLK}	SPI clock period	33.3	-	33.3	-	33.3	-	ns
T_{SCLKL}	SPI clock low duration	13	-	13	-	13	-	
T_{SCLKH}	SPI clock high duration	13	-	13	-	13	-	
T_{SAC}	SPI access time	4	-	3.5	-	3	-	
T_{ISU}	Input setup	4	-	3.5	-	3	-	
T_{IH}	Input Hold	0	-	0	-	0	-	
T_{ZO}	Output enable delay	-	16	-	13	11	-	
T_{OZ}	Output disable delay	-	13	-	11	10	-	
T_{OD}	Output data delay	-	15	-	12	11	-	
T_{CSNH}	CSN hold time	0	-	0	-	0	-	

For more information about BT820B controller please go to official BT820 website.

<https://brtchip.com/product/bt820b/>

10.4 Backlight driver block diagram

Backlight enable signal is internally connected to BT820B backlight control pin. This pin is controlled by two BT820B's registers. **REG_PWM_HZ** specifies the PWM output frequency. The recommended PWM backlight frequency ranges from 5kHz to 10kHz. **REG_PWM_DUTY** specifies the duty cycle.

Refer to BT820B datasheet for more information.

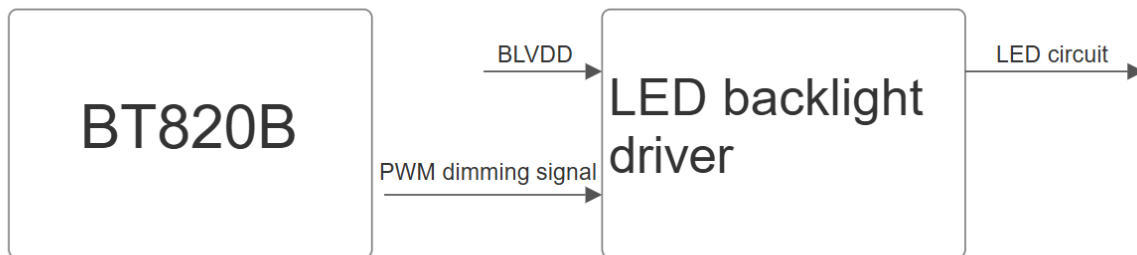

Figure 10. Backlight driver block diagram.

The LED backlight driver used in this module does not burst the LED current. Therefore, it does not generate audible noises on the output capacitor. It is equipped with start subsystem, which increases LED lifetime, as LED current peaks are reduced significantly.

11. 1024Mb NOR FLASH MEMORY

The Riverdi EVE5 15.6" series modules are built with a 1024Mb NOR flash memory chip. Graphics assets such as fonts, audio and images can be stored in the flash memory. Up to full HD resolution (1920x1080 pixels, JPG) images can be stored.

12. TFT TIMING CHARACTERISTICS

The TFT of the module applies Riverdi high brightness, IPS, full HD, 15.6" LVDS TFT: RVT156HKLNWCA0-B.

For detailed information of the display, please refer to datasheet of the display.

13. CAPACITIVE TOUCH SCREEN PANEL SPECIFICATIONS

13.1 Mechanical characteristics

DESCRIPTION	SPECIFICATION	REMARK
Touch Panel Size	360.10 mm x 212.40 mm	αTouch
Outline Dimension of CTP	2.95 mm	
Product Thickness	1.8 mm	
CTP View Area	344.16 mm x 193.59 mm	
Sensor Active Area	345.76 mm x 194.19 mm	
Surface Hardness	6H	

13.2 Electrical characteristics

DESCRIPTION	SPECIFICATION	REMARK
Linearity	+/-1.5mm	
Controller	ILI2510	
Resolution	1920 x 1080	

14. INSPECTION

Standard acceptance/rejection criteria for TFT module according to document available [here](#).

15. RELIABILITY TEST

NO.	TEST ITEM	TEST CONDITION	NOTE
1	High Temperature Storage	80°C/120 hours	Note 1
2	Low Temperature Storage	-30°C/120 hours	
3	High Temperature Operating	70°C/120 hours	
4	Low Temperature Operating	-20°C/120 hours	
5	High Temperature and High Humidity	40°C, 90%RH, 120Hrs	
7	Thermal Cycling Test (No operation)	-20°C for 30min, 70°C for 30 min. 100 cycles. Then test at room temperature after 1 hour	Note 2
8	Vibration Test	Frequency: 10 ÷ 55 Hz. Stroke: 1.5 mm. Sweep: 10Hz ÷ 55Hz ÷ 10 Hz. 2 hours for each direction of X, Y, Z (Total 6 hours)	
9	Package Drop Test	Height: 60 cm 1 corner, 3 edges, 6 surfaces	

Note 1. Sample quantity for each test item is 5 ÷ 10 pcs.

Note 2. The device is kept at room temperature for 2 hours prior to starting the test

16. LEGAL INFORMATION

CE marking is usually obligatory only for a complete end product. Riverdi display modules are semi-finished goods which are used as inputs to become part of the finished products.

Therefore, Riverdi display modules are not CE marked.

This is not a standalone product. It was designed as an electronic component. It needs integration with a whole system to be fully functional.

Riverdi grants the guarantee for the proper operation of the goods for a period of 12 months from the date of possession of the goods. If in a consequence of this guaranteed execution the customer has received the defects-free item as replacement for the defective item, the effectiveness period of this guarantee shall start anew from the moment the customer receives the defects-free item.

Information about device is the property of Riverdi and may be the subject of patents pending or granted. It is not allowed to copy or disclosed this document without prior written permission.

Riverdi endeavors to ensure that all contained information in this document is correct but does not accept liability for any error or omission. Riverdi products are in developing process and published information may be not up to date. Riverdi reserves the right to update and makes changes to Specifications or written material without prior notice at any time. It is important to check the current position with Riverdi.

Images and graphics used in this document are only for illustrative the purpose. All images and graphics are possible to be displayed on the range products of Riverdi, however the quality may vary. Riverdi is no liable to the buyer or to any third party for any indirect, incidental, special, consequential, punitive, or exemplary damages (including without limitation lost profits, lost savings, or loss of business opportunity) relating to any product, service provided or to be provided by Riverdi, or the use or inability to use the same, even if Riverdi has been advised of the possibility of such damages.

Riverdi products are not fault tolerant nor designed, manufactured or intended for use or resale as on line control equipment in hazardous environments requiring fail-safe performance, such as in the operation of nuclear facilities, aircraft navigation or communication systems, air traffic control, direct life support machines or weapons systems in which the failure of the product could lead directly to death, personal injury or severe physical or environmental damage ('High-Risk Activities'). Riverdi and its suppliers specifically disclaim any expressed or implied warranty of fitness for High-Risk Activities. Using Riverdi products and devices in 'High-Risk Activities' and in any other application is entirely at the buyer's risk, and the buyer agrees to defend, indemnify and hold harmless Riverdi from all damages, claims or expenses resulting from such use. No licenses are conveyed, implicitly or otherwise, under any Riverdi intellectual property rights.

17. CONTACT

Your Success is Our Priority

Stuck on a technical challenge? Need expert guidance?
Our dedicated support team is just a message away.

Contact us at

contact@riverdi.com

We're here to ensure your project's success, every step of the way!