

Revision:	Changes:	Date:
1.0	Initial Case	2024.03.27
1.1	Changed the CG VA dimension	2025.02.03

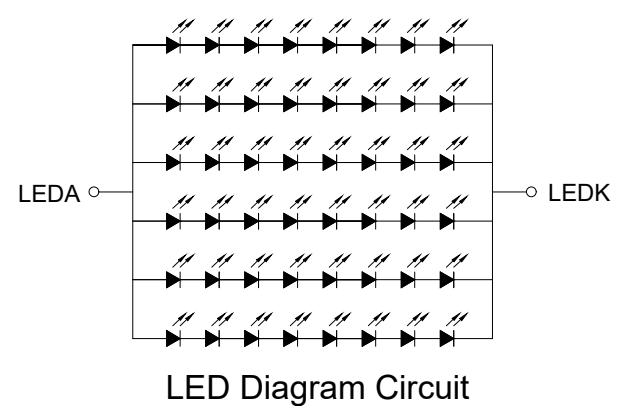
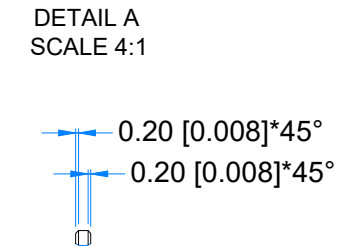
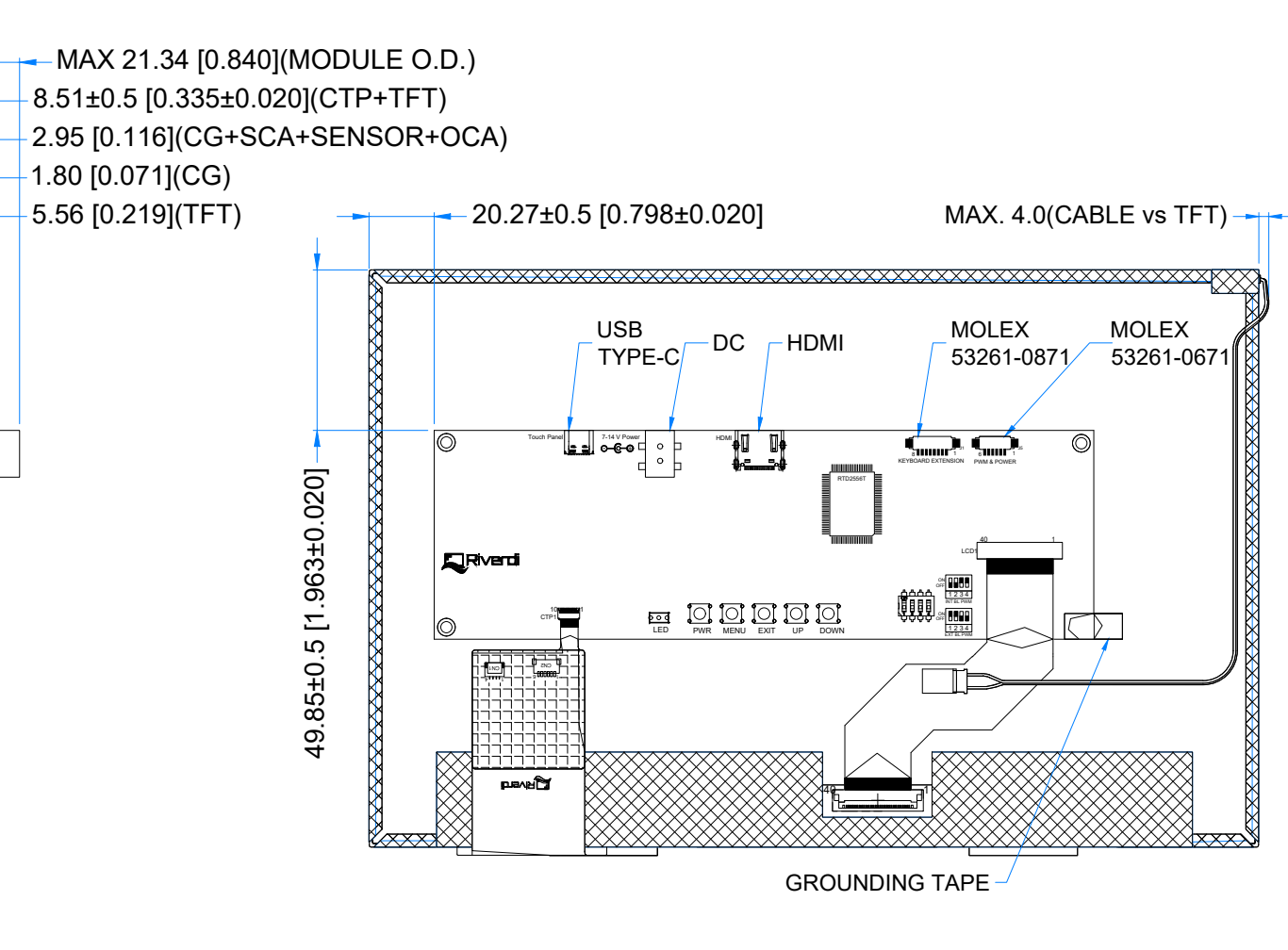
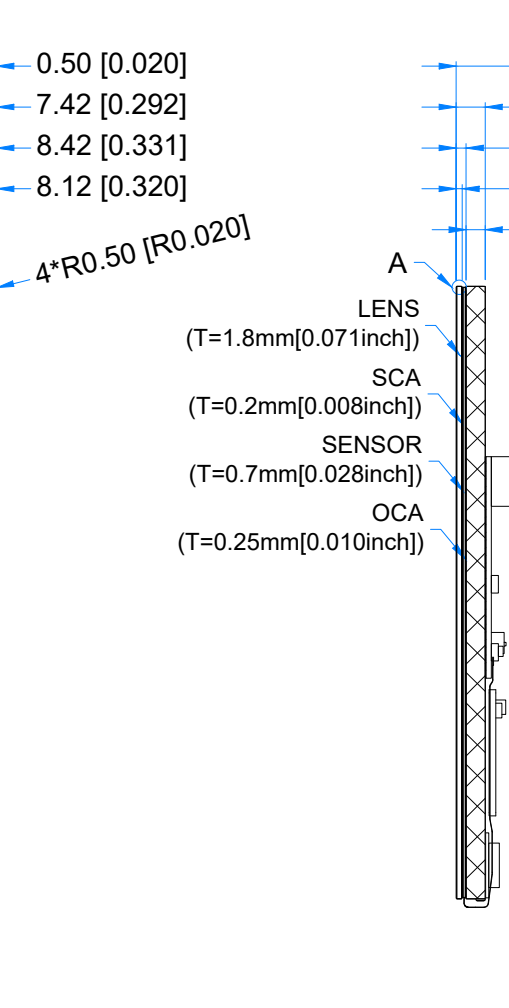
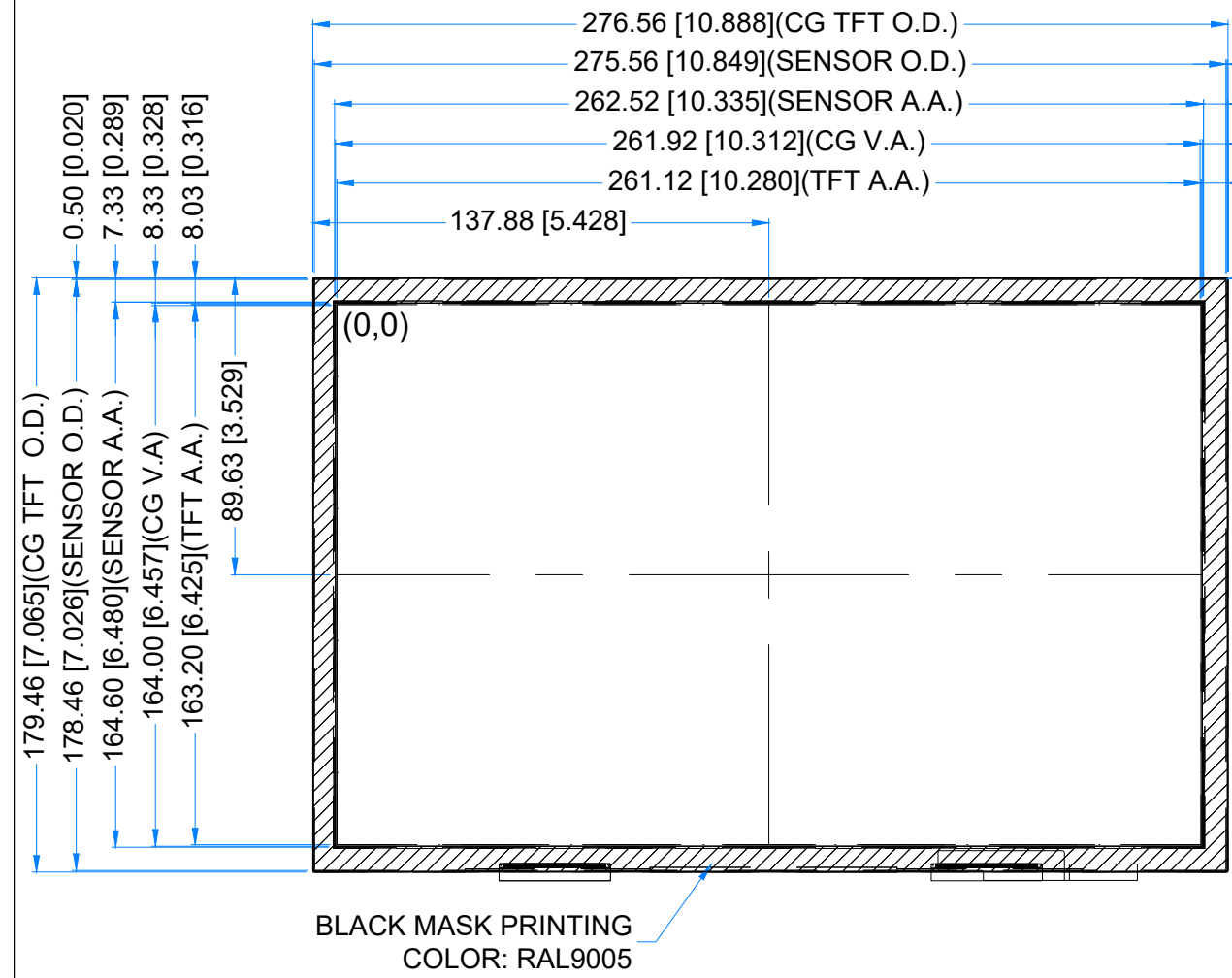

PINOUT ON THE 2ND PAGE

**LCM NOTES:**

- LCD TYPE: TRANSMISSIVE, NORMALLY BLACK, IPS
- RESOLUTION: 1280x800
- VIEWING ANGLE: FREE
- CONTROLLER IC OF MAIN BOARD: RTD2556QR
- VIDEO INTERFACE: HDMI
- POWER SUPPLY: POWER JACK (7.0-14.0V)
- MODULE SURFACE LUMINANCE: 850cd/m<sup>2</sup>

**TP NOTES:**

- TP STRUCTURE: G+G
- CG THICKNESS: 1.8mm[0.071inch]
- SURFACE HARDNESS: 6H
- DRIVER IC: ILI2511
- INTERFACE: USB-C

**GENERAL NOTES:**

- OPERATING TEMPERATURE: -20°C ~ 70°C
- STORAGE TEMPERATURE: -30°C ~ 80°C
- WITHOUT INDIVIDUAL TOLERANCE: ±0.3mm[0.012inch]
- RoHS3 COMPLIANT

PN: RVT121HVHNWCA0-B

SN:

DRAWN: M.Suchocki

CHECKED: M.Wierzbowski

APPR:

**Riverdi**

2025.02.03

1:2.22

2025.02.03

[mm]

ISO A3

P. 1 of 1



EXTERNAL KEYBOARD CONNECTOR - J1			
Pin No.	Desc.	Pin No.	Desc.
1	DOWN	2	UP
3	EXIT	4	MENU
5	PWR	6	LED_EN
7	GND	8	KEYBOARD VDD

BACKLIGHT PWM & POWER - J5			
Pin No.	Desc.	Pin No.	Desc.
1	GND	2	GND
3	EN	4	PWM
5	VDD	6	VDD