

Revision:	Changes:	Date:
1.0	Initial Case	2024.04.11
1.1	Changed the CG VA dimension	2025.02.03

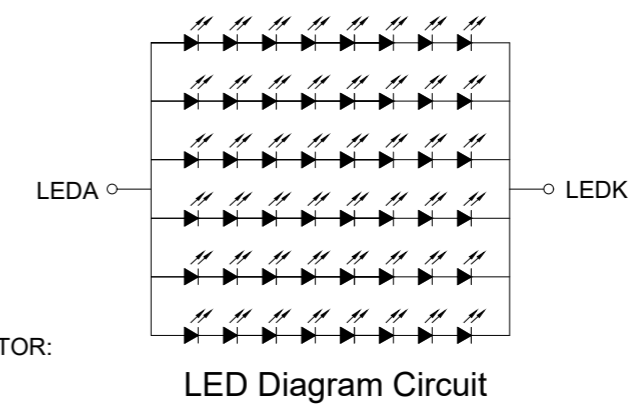
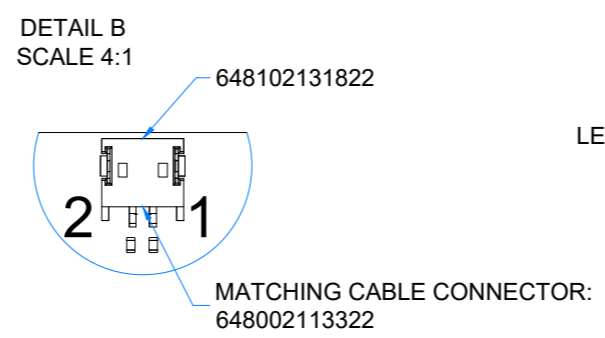
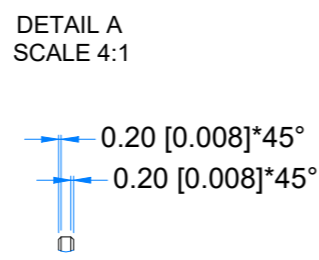
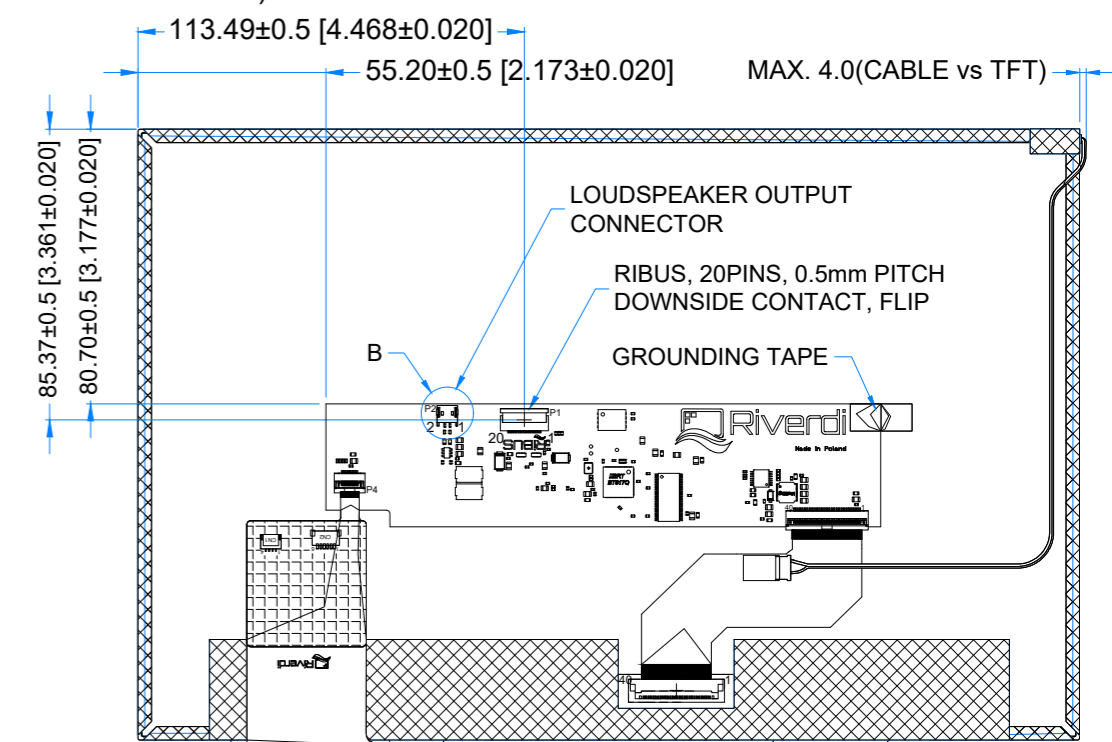
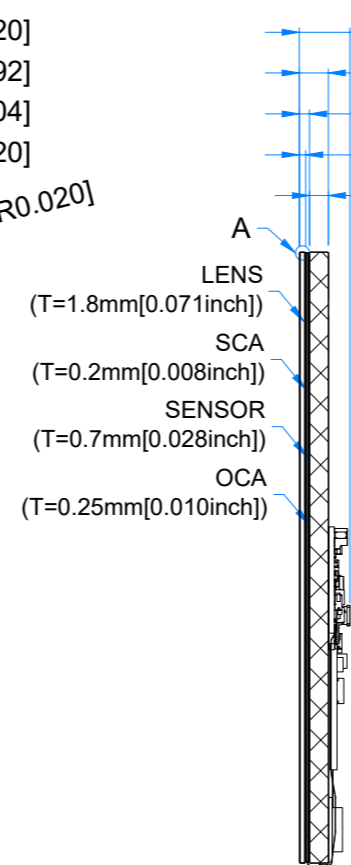
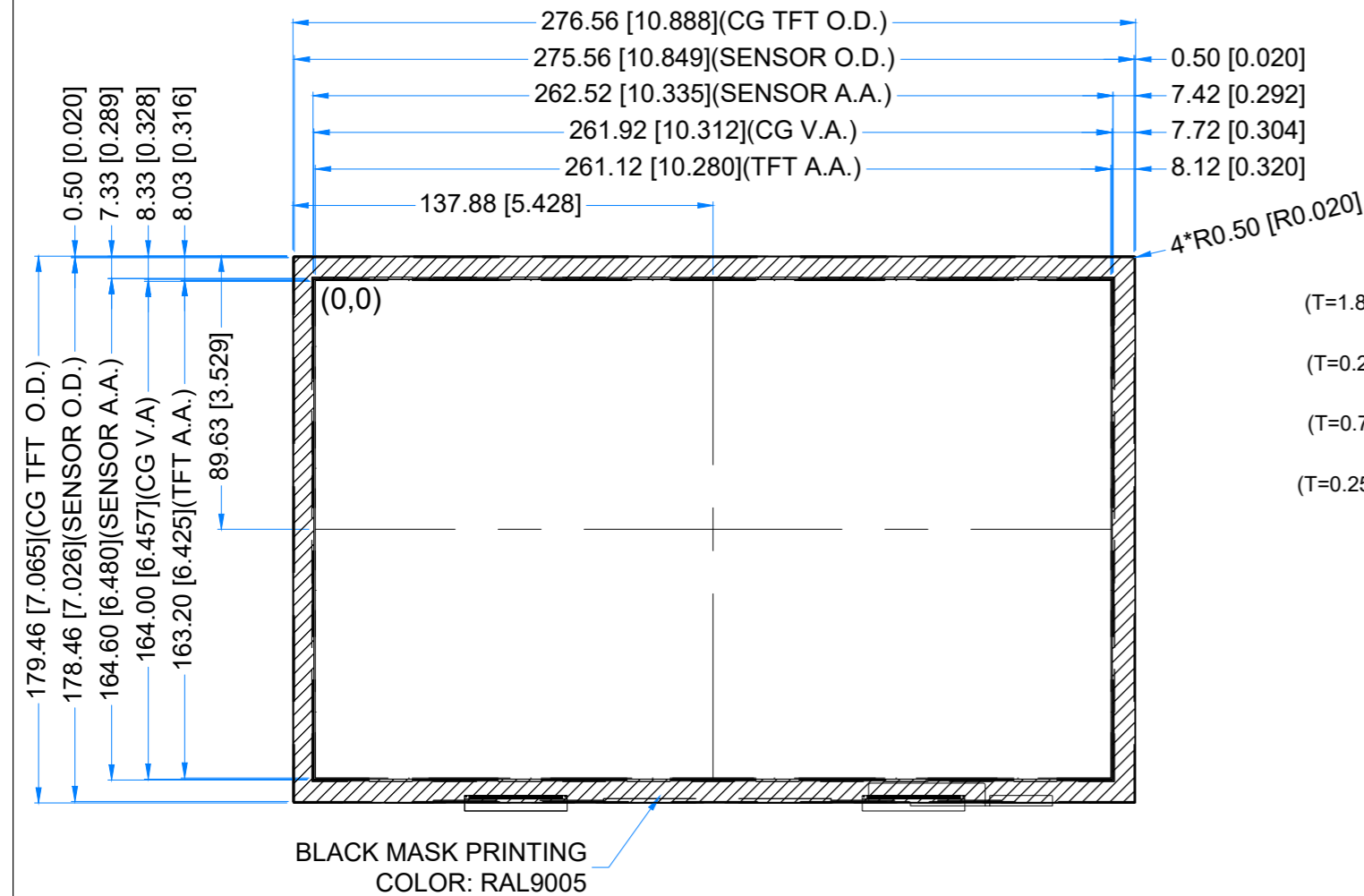

PINOUT ON THE 2ND PAGE

LCD NOTES:

- LCD TYPE: TRANSMISSIVE, NORMALLY BLACK, IPS
- RESOLUTION: 1280x800
- VIEWING ANGLE: FREE
- SURFACE LUMINANCE: 850 cd/m²
- DRIVING IC ON THE BOARD: BT817Q
- INTERFACE: SPI/QSPI
- SUPPLY VOLTAGE FOR MODULE: 3.3 V
- SUPPLY VOLTAGE FOR BACKLIGHT: 7.0 ÷ 14.0 V, BUILT-IN LED INVERTER

TP NOTES:

- TP STRUCTURE: G+G
- CG THICKNESS: 1.8mm[0.071inch]
- SURFACE HARDNESS: 6H
- DRIVER IC: ILI2511
- INTERFACE: SPI/QSPI VIA RIBUS AND BT817Q

GENERAL NOTES:

- OPTICAL BONDING BETWEEN TFT AND CTP
- OPERATING TEMPERATURE: -20°C ~ 70°C
- STORAGE TEMPERATURE: -30°C ~ 80°C
- WITHOUT INDIVIDUAL TOLERANCE: ±0.3mm[0.012inch]
- RoHS3 COMPLIANT

PN: RVT121HVBWCA0-B

SN:

DRAWN: M.Suchocki 2025.02.03

CHECKED: M.Wierzbowski 2025.02.03

APPR:

2025.02.03 1:2.22

[mm]

ISO A3 P. 1 of 1



P1-RIBUS CONNECTOR			
Pin No.	Desc.	Pin No.	Desc.
1	VDD	11	GPIO.1/IO.2
2	GND	12	GPIO.2/IO.3
3	SPI_SCLK	13	NC
4	MISO/IO.1	14	NC
5	MOSI/IO.0	15	NC
6	CS	16	NC
7	INT	17	BLVDD
8	RST/PD	18	BLVDD
9	GPIO.0	19	BLGND
10	DISP_AUDIO	20	BLGND

P2-LOUDSPEAKER OUTPUT CONNECTOR			
Pin No.	Desc.	Pin No.	Desc.
1	SPEAKER+	2	SPEAKER-