



RVA35HI-NUC144A

HB, IPS 3.5" LCD TFT DATASHEET

Rev.1.3
2025-01-14

ITEM	CONTENTS	UNIT
LCD Type	TFT/Transmissive/Normally black/IPS	/
Size	3.5	Inch
Viewing Direction	Free	/
Outside Dimensions (W x H x D)	98.34 x 70.40 x 18.80	mm
Active Area (W x H)	73.44 x 48.96	mm
Pixel Pitch (W x H)	0.153 x 0.153	mm
Resolution	320 (RGB) x 480	/
Brightness	1200	cd/m ²
LCD Interface Type	RGB / SPI	/
LCD Driver	ILI9488	
Color Depth	262K	/
Pixel Arrangement	RGB Vertical Stripe	/
With/Without Touch	With Projected Capacitive Touch Panel	/
CTP Driver	ILI2130	/
Touch Interface Type	I2C	/
Bonding Technology	Optical Bonding	/
Weight	170	g

Note 1. RoHS3 compliant

Note 2. LCM weight tolerance: ± 5%.



1. REVISION RECORD

REV NO.	REV DATE	CONTENTS	REMARKS
1.0	2024-06-19	First Release	
1.1	2024-08-26	Corrected the schematic	
1.2	2024-11-07	PCB Update	
1.3	2025-01-14	Part Number Update	



2. CONTENTS

- 1. REVISION RECORD..... 2
- 2. CONTENTS..... 3
- 3. MODULE CLASSIFICATION INFORMATION..... 4
- 4. MODULE DRAWING..... 5
- 5. ABSOLUTE MAXIMUM RATINGS..... 6
- 6. ELECTRICAL CHARACTERISTICS..... 6
- 7. BACKLIGHT ELECTRICAL CHARACTERISTICS..... 6
- 8. ELECTRO-OPTICAL CHARACTERISTICS..... 7
- 9. INTERFACES DESCRIPTION..... 9
 - 9.1 CN7..... 10
 - 9.2 CN8..... 10
 - 9.3 CN9..... 10
 - 9.4 CN10..... 11
- 10. EXTERNAL MEMORY..... 11
- 11. CAPACITIVE TOUCH SCREEN PANEL SPECIFICATIONS..... 11
 - 11.1 Mechanical characteristics..... 11
 - 11.2 Electrical characteristics..... 11
- 12. INSPECTION..... 12
 - 12.1 Inspection condition..... 12
 - 12.2 Inspection standard..... 13
- 13. LEGAL INFORMATION..... 14



3. MODULE CLASSIFICATION INFORMATION

RV	A	35	H	I	NUC	144	A
1.	2.	3.	4.	5.	6.	7.	8.

NO.	PARAMETER	SYMBOL
1.	BRAND	RV – Riverdi
2.	PRODUCT TYPE	A – Accessories
3.	DISPLAY SIZE	35 – 3.5"
4.	MODEL SERIAL NO.	H – High Brightness, IPS
5.	RESOLUTION	I – 320 x 480 px
6.	INTERFACE	NUC – goldpins for Nucleo board, RGB - display, I2C – touch panel
7.	NUMBER OF PINS	144
8.	VERSION	A – 8MB NOR Flash memory

Revision:	Changes:	Date:
1.0	Initial Case	2024.06.19
1.1	PCB Update	2024.11.07
1.2	Part Number Update	2025.01.14

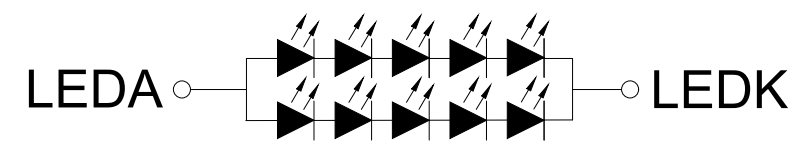
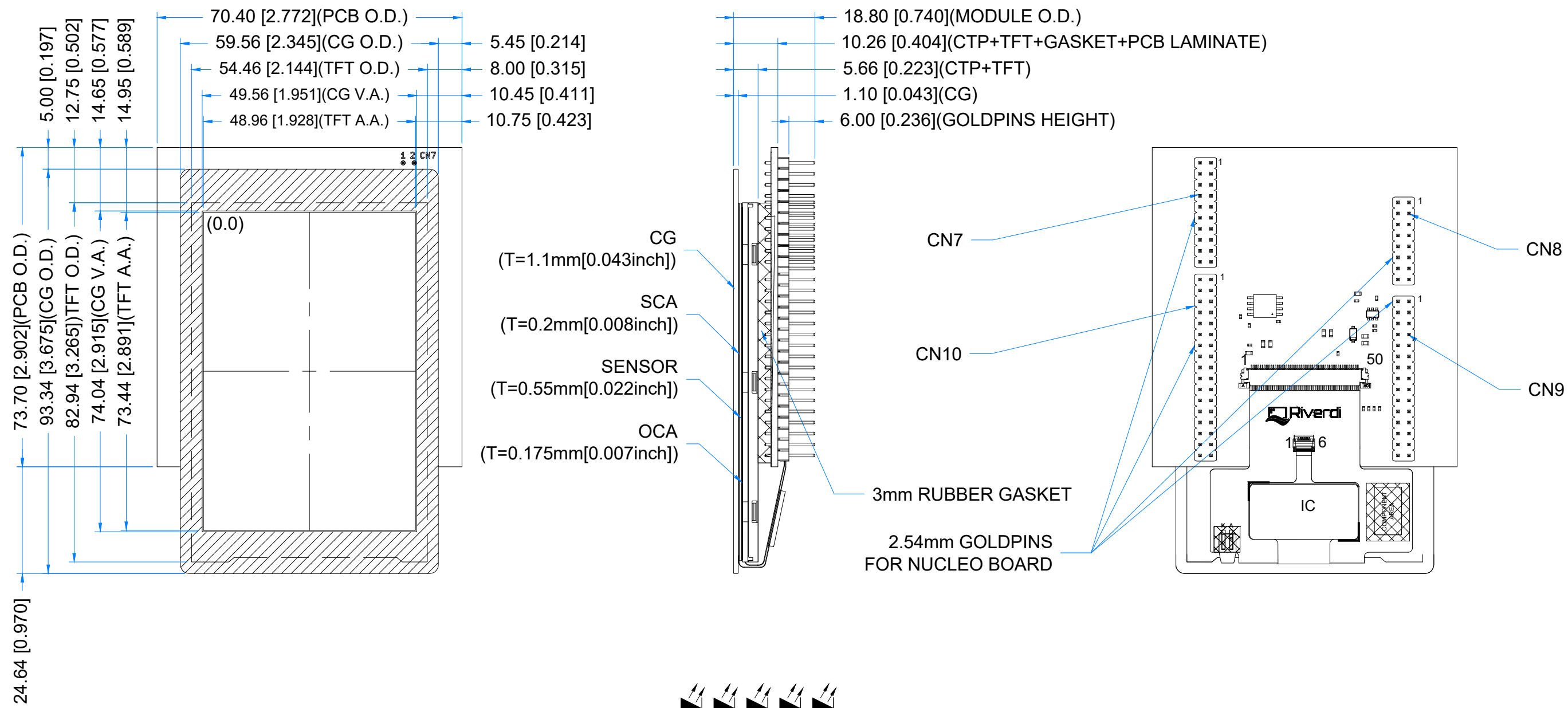

Backlight Circuit Diagram

TFT NOTES:

1. DISPLAY TYPE: TFT, TRANSMISSIVE, NORMALLY BLACK
2. RESOLUTION: 320x480
3. VIEWING ANGLE: FREE
4. SURFACE LUMINANCE: 1200cd/m²
5. BACKLIGHT: 10 LEDS

TP NOTES:

1. TP STRUCTURE: G+G
2. DRIVER IC: ILI2130
3. SURFACE HARDNESS:>6H

GENERAL NOTES:

1. OPERATING TEMPERATURE: -20°C ~ 70°C
2. STORAGE TEMPERATURE: -30°C ~ 80°C
3. WITHOUT INDIVIDUAL TOLERANCE: ±0.3mm
4. RoHS COMPLIANT

PN: RVA35HI-NUC144A			
SN:			
DRAWN: M.Natywa	2024.11.07	1:1.00	
CHECKED: M.Wierzbowski	2025.01.14	[mm]	
APPR:		ISO A3	



5. ABSOLUTE MAXIMUM RATINGS

PARAMETER	SYMBOL	MIN	MAX	UNIT	NOTE
Supply Voltage for Module	VDD	-0.3	3.3	V	Note 1
Digital I/O signals (SPI/QSPI/GPIO) Voltage	IOVCC	-0.3	3.3		
Supply voltage for Backlight	BLVDD	-0.3	6.0		
Operating Temperature	T _{OP}	-20	70	°C	
Storage Temperature	T _{ST}	-30	80	°C	
Storage Humidity (@ 25 ± 5°C)	H _{ST}	10	-	% RH	
Operating Ambient Humidity (@ 25 ± 5°C)	H _{OP}	10	-	% RH	

Note 1. The absolute maximum rating values must not be exceeded at any times. The module MUST NOT be used when any of the absolute maximum ratings is exceeded. The characteristics of the module may not be recovered, or in an extreme case, the module may be permanently destroyed.

6. ELECTRICAL CHARACTERISTICS

PARAMETER	SYMBOL	MIN	TYP	MAX	UNIT
Supply Voltage	VCC	2.5	2.8	3.3	V
Supply Current	ICC	-	50	-	mA
Interface Supply Voltage	IOVCC	1.7	1.8	3.3	V
Input High Voltage for LCD	VIH	0.7*IOVCC	-	IOVCC	V
Input Low Voltage for LCD	VIL	-0.3	-	0.3*IOVCC	V
Output High Voltage for LCD	VOH	0.8*IOVCC	-	IOVCC	V
Output Low Voltage for LCD	VOL	-0.3	-	0.3*IOVCC	V

7. BACKLIGHT ELECTRICAL CHARACTERISTICS

PARAMETER	SYMBOL	MIN	TYP	MAX	UNIT	NOTE
Backlight Driving Voltage	VLED	2.7	5	5.5	V	
Backlight Driving Current	ILED	-	200	-	mA	Note 3
LED Lifetime	-	-	30,000	-	hours	Note 1,2

Note 1. Optical performance should be evaluated at T_a=25 °C only.

Note 2. Operating life means the period in which the LED brightness goes down to 50% of the initial brightness. Typical operating lifetime is the estimated parameter.

Note 3. Current measured with 100% backlight intensity.



8. ELECTRO-OPTICAL CHARACTERISTICS

ITEM	SYMBOL	CONDITION	MIN	TYP	MAX	UNIT	RMK	NOTE	
Response Time	Tr+Tf	θ=0° φ=0° Ta=25 °C	-	30	-	ms	FIG 1.	4	
Contrast Ratio	Cr		-	700	-	---	FIG 2	1	
Surface Luminance	Lv		-	1200	-	cd/m ²		2	
Viewing Angle Range	θ	Ta=25 °C	φ = 90°	-	80	-	FIG 3.	6	
			φ = 270°	-	80	-			deg
			φ = 0°	-	80	-			deg
			φ = 180°	-	80	-			deg
CIE (x, y) Chromaticity	Rx	θ=0° φ=0° Ta=25 °C	-	0.660	-	-	FIG 2.	5	
	Ry		-	0.325	-	-			
	Gx		-	0.277	-	-			
	Gy		-	0.568	-	-			
	Bx		-	0.145	-	-			
	By		-	0.072	-	-			

Note 1. Contrast Ratio (CR) is defined mathematically as below, for more information see Figure 2.

$$\text{Contrast Ratio} = \frac{\text{Average Surface Luminance with all white pixels (P1, P2, P3, P4, P5)}}{\text{Average Surface Luminance with all black pixels (P1, P2, P3, P4, P5)}}$$

Note 2. Surface luminance is the LCD surface from the surface with all pixels displaying white. For more information see Figure 2.

$$L_v = \text{Average Surface Luminance with all white pixels (P1, P2, P3, P4, P5)}$$

Note 3. The uniformity in surface luminance δ WHITE is determined by measuring luminance at each test position 1 through 5, and then dividing the minimum luminance of 5 points luminance by maximum luminance of 5 points luminance. For more information see Figure 2.

$$\delta \text{ WHITE} = \frac{\text{Minimum Surface Luminance with all white pixels (P1, P2, P3, P4, P5)}}{\text{Maximum Surface Luminance with all white pixels (P1, P2, P3, P4, P5)}}$$

Note 4. Response time is the time required for the display to transition from white to black (Rise Time, Tr) and from black to white (Decay Time, Tf). For additional information see Figure 1. The test equipment is BM-7A.

Note 5. CIE (x, y) chromaticity, the x, y value is determined by measuring luminance at each test position 1 through 5, and then make average value.

Note 6. For TFT module the contrast ratio is greater than 10. The angles are determined for the horizontal or x axis and the vertical or y axis with respect to the z axis which is normal to LCD surface. For more information see Figure 3.

Note 7. Viewing angle is measured at the center point of the LCD by CONOSCOPE (ergo-80). For response time testing, the testing data is based on BM-7A. Instruments for Contrast Ratio, Surface Luminance, Luminance Uniformity, Chromaticity the test data is based on SR-3A.

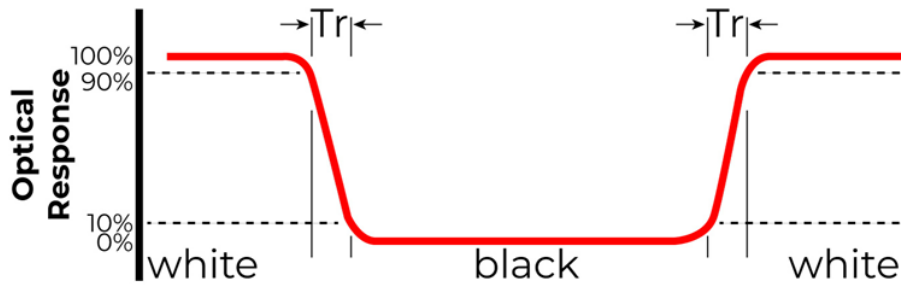
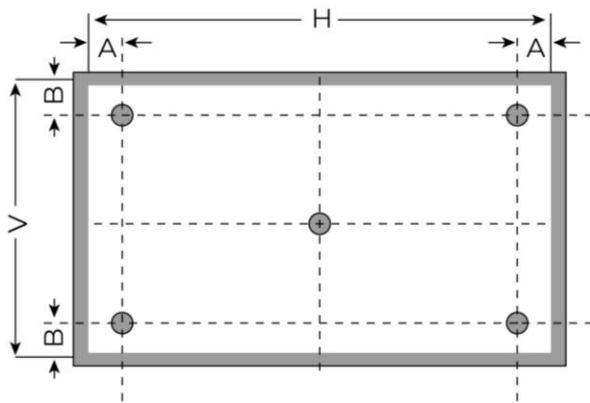

Figure 1. The definition of response time



A: 5mm

B: 5mm

H, V: Active Area

Light spot size $\varnothing=5\text{mm}$, 500mm distance from the LCD surface to detector lens.

Measurement instrument is TOPCON'S luminance meter BM-5

Figure 2. Measuring method for Contrast ratio, surface luminance, Luminance uniformity, CIE (x, y) chromaticity

Figure 3. The definition of viewing angle

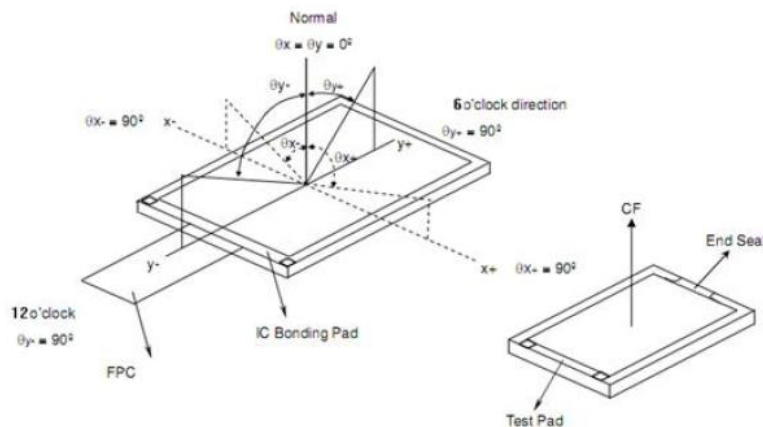



9. INTERFACES DESCRIPTION

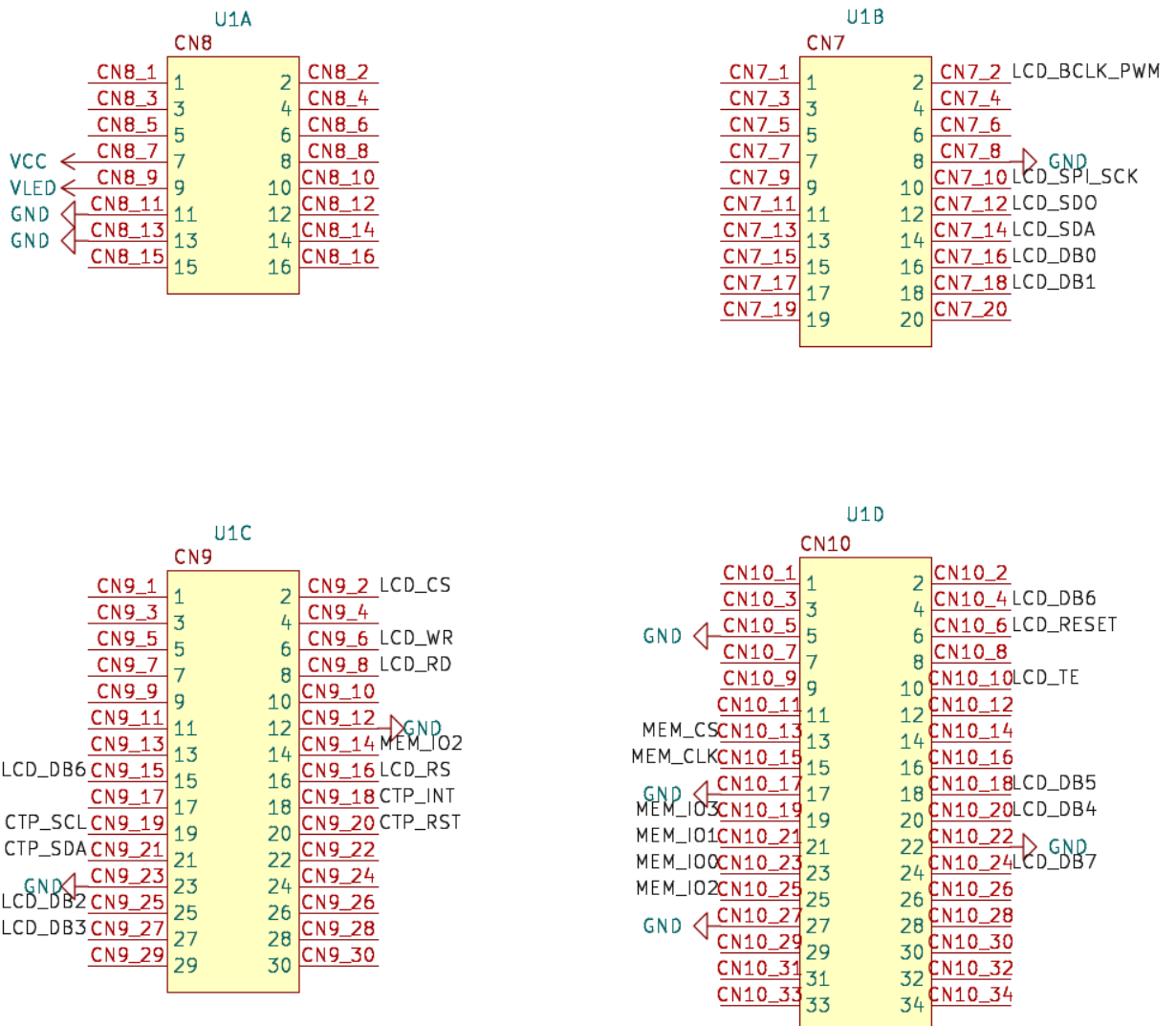



9.1 CN7

NO.	SYMBOL	DESCRIPTION	I/O
2	LCD_BCLK_PWM	Backlight PWM	I
8	GND	Ground	P
10	LCD_SPI_SCK	SPI serial clock	I
12	LCD_SDO	SPI serial data output	O
14	LCD_SDA	SPI serial data	I/O
16	LCD_DB0	Data bus	I/O
18	LCD_DB1	Data bus 1	I/O

9.2 CN8

NO.	SYMBOL	DESCRIPTION	I/O
7	VCC	Power Supply 3.3V	P
9	VLED	Backlight Power Supply	P
11	GND	Ground	P
13	GND	Ground	P

9.3 CN9

NO.	SYMBOL	DESCRIPTION	I/O
2	LCD_CS	LCD chip select signal	I
6	LCD_WR	LCD WRITE ENABLE	I
8	LCD_RD	LCD OUTPUT ENABLE	I
12	GND	Ground	P
14	MEM_IO2	OCTOSPI data 2	I/O
15	LCD_DB6	Data bus 6	I/O
16	LCD_RS	LCD Data/Command	I
18	CTP_INT	CTP Interrupt	O
19	CTP_SCL	CTP Serial clock	I
20	CTP_RST	CTP Reset	I
21	CTP_SDA	CTP Serial data	I/O
23	GND	Ground	P
25	LCD_DB2	Data bus 2	I/O
27	LCD_DB3	Data bus 3	I/O



9.4 CN10

NO.	SYMBOL	DESCRIPTION	I/O
4	LCD_DB6	Data bus 6	I/O
5	GND	Ground	P
6	LCD_RESET	LCD reset	I
10	LCD_TE	LCD Tearing Effect	O
13	MEM_CS	OCTOSPI chip select	I
15	MEM_CLK	OCTOSPI clock	I/O
17	GND	Ground	P
18	LCD_DB5	Data bus 5	I/O
19	MEM_IO3	OCTOSPI data 3	I/O
20	LCD_DB4	Data bus 4	I/O
21	MEM_IO1	OCTOSPI data 1	I/O
22	GND	Ground	P
23	MEM_IO0	OCTOSPI data	I/O
24	LCD_DB7	Data bus 7	I/O
25	MEM_IO2	OCTOSPI data 2	I/O
27	GND	Ground	P

10. EXTERNAL MEMORY

ITEM	DESCRIPTION
Flash	NOR Flash
Size	64Mbit/8Mbyte
Interface	OCTOSPI

11. CAPACITIVE TOUCH SCREEN PANEL SPECIFICATIONS

11.1 Mechanical characteristics

DESCRIPTION	SPECIFICATION	REMARK
Touch Panel Size	3.5 inch	
Outline Dimension of CTP	59.56 mm x 93.34 mm	
Glass Thickness	1.1 mm	
CTP View Area	49.56 mm x 74.04 mm	
Sensor Active Area	48.96mm x 73.44 mm	
Surface Hardness	6H	

11.2 Electrical characteristics

DESCRIPTION	SPECIFICATION	REMARK
Controller	ILI2130	
Resolution	320 x 480	
Device address 7-bit	0x41	

12. INSPECTION

Standard acceptance/rejection criteria for TFT module

12.1 Inspection condition

Ambient conditions:

- Temperature: $25 \pm 2^{\circ}\text{C}$
- Humidity: $(60 \pm 10) \% \text{RH}$
- Illumination: Single fluorescent lamp non-directive (300 to 700 lux)

Viewing distance: $35 \pm 5\text{cm}$ between inspector bare eye and LCD.

Viewing Angle: U/D: $45^{\circ}/45^{\circ}$, L/R: $45^{\circ}/45^{\circ}$

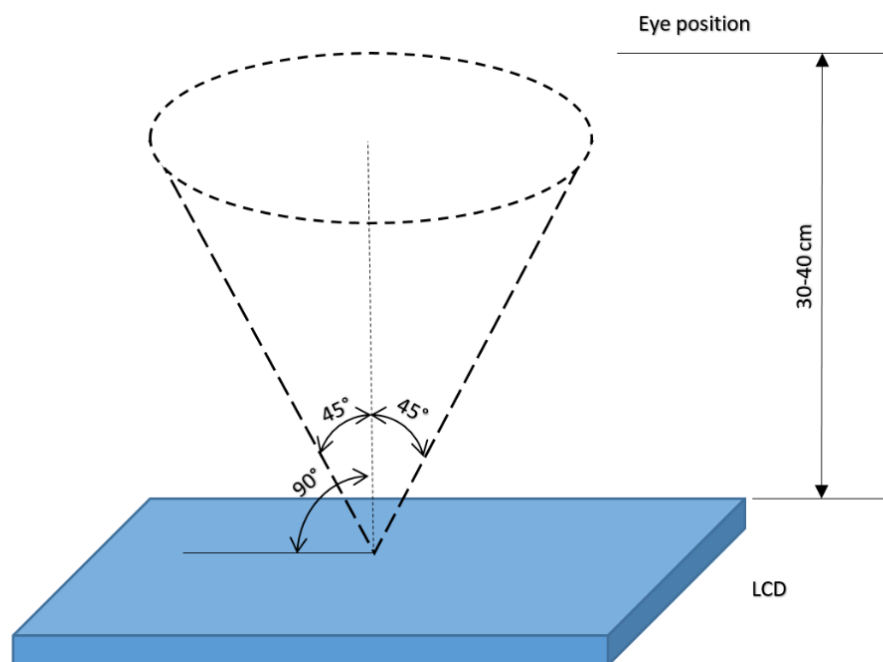



12.2 Inspection standard

The LCD TFT has zero bad pixels. Please refer the item “Bright/Dark dots”.

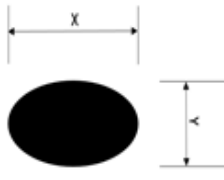
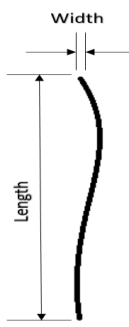
ITEM		CRITERION		
Black spots, white spots, light leakage, Foreign Particle (round Type)	 <p>$D=(x+y)/2$ Spots density: 10 mm</p>	Size < 5"		
		Average Diameter		Qualified Qty
		$D \leq 0.2$ mm		Ignored
		$0.2 \text{ mm} < D \leq 0.3 \text{ mm}$		$N = 0$
		$0.5\text{mm} < D$		$N = 0$
LCD black spots, white spots, light leakage (line Type)	 <p>Spots density: 10 mm</p>	Size < 5"		
		Length	Width	Qualified Qty
		$L \leq 1.8$	$W \leq 0.05$	Ignored
		$L \leq 0.8$	$0.05 < W \leq 0.1$	$N \leq 3$
		-	$W > 0.1$	Not allowed
Bright/Dark Dots	Size < 5"			
	Item		Qualified Qty	
	Bright dots		1	
	Dark dots		1	
Total Bright and Dark Dots		1		
Clear spots	Size < 5"			
	Average Diameter		Qualified Qty	
	$D < 0.2$ mm		Ignored	
	$0.2 \text{ mm} < D < 0.3 \text{ mm}$		4	
	$0.3 \text{ mm} < D < 0.5 \text{ mm}$		2	
	$0.5 \text{ mm} < D$		0	
Spots density: 10 mm				
Touch panel spots	Size < 5"			
	Average Diameter		Qualified Qty	
	$D < 0.025$ mm		$N \leq 2$	
	$0.025 \text{ mm} < D < 0.5 \text{ mm}$		$N \leq 1$	
$0.5 \text{ mm} < D$		Not allowed		
Touch panel white line scratch	Size < 5"			
	Length	Width	Qualified Qty	
	-	$W \leq 0.025$	$N \leq 2$	
	$L \leq 5.0$	$0.025 < W < 0.05$	$N \leq 1$	
-	$0.05 < W$	Not allowed		



13. LEGAL INFORMATION

CE marking is usually obligatory only for a complete end product. Riverdi display modules are semi-finished goods which are used as inputs to become part of the finished products.

Therefore, Riverdi display modules are not CE marked.

Riverdi grants the guarantee for the proper operation of the goods for a period of 12 months from the date of possession of the goods. If in a consequence of this guaranteed execution the customer has received the defects-free item as replacement for the defective item, the effectiveness period of this guarantee shall start anew from the moment the customer receives the defects-free item.

Information about device is the property of Riverdi and may be the subject of patents pending or granted. It is not allowed to copy or disclosed this document without prior written permission.

Riverdi endeavors to ensure that all contained information in this document is correct but does not accept liability for any error or omission. Riverdi products are in developing process and published information may be not up to date. Riverdi reserves the right to update and makes changes to Specifications or written material without prior notice at any time. It is important to check the current position with Riverdi.

Images and graphics used in this document are only for illustrative the purpose. All images and graphics are possible to be displayed on the range products of Riverdi, however the quality may vary. Riverdi is no liable to the buyer or to any third party for any indirect, incidental, special, consequential, punitive or exemplary damages (including without limitation lost profits, lost savings, or loss of business opportunity) relating to any product, service provided or to be provided by Riverdi, or the use or inability to use the same, even if Riverdi has been advised of the possibility of such damages.

Riverdi products are not fault tolerant nor designed, manufactured or intended for use or resale as on line control equipment in hazardous environments requiring fail-safe performance, such as in the operation of nuclear facilities, aircraft navigation or communication systems, air traffic control, direct life support machines or weapons systems in which the failure of the product could lead directly to death, personal injury or severe physical or environmental damage ('High-Risk Activities'). Riverdi and its suppliers specifically disclaim any expressed or implied warranty of fitness for High-Risk Activities. Using Riverdi products and devices in 'High-Risk Activities' and in any other application is entirely at the buyer's risk, and the buyer agrees to defend, indemnify and hold harmless Riverdi from all damages, claims or expenses resulting from such use. No licenses are conveyed, implicitly or otherwise, under any Riverdi intellectual property rights.

Hi, I am here to help you!
If you have any additional
questions, please contact
our support via email:
contact@riverdi.com

