



TFT MODULE SPECIFICATION

## **RVT15MDTNWC00-B**

HB, IPS 1.54" LCD TFT display datasheet

Rev. 1.0

2024-11-26

---

**Riverdi Sp. z o.o.**

Nowy Swiat 36  
80-299 Gdansk, Poland  
VAT ID: PL5842767153

Registration number (KRS): 0000923967

**+48 587 703 116**

Office hours: 9:00 to 17:30 CET (Mon-Fri)

**[contact@riverdi.com](mailto:contact@riverdi.com)**

**[riverdi.com](http://riverdi.com)**



ITEM	CONTENTS	UNIT
LCD Type	TFT/Transmissive/Normally Black/IPS	/
Size	1.54	Inch
Viewing Direction	Free	/
Outside Dimensions (W x H x D)	36.00 x 43.00 x 3.54	mm
Active Area (W x H)	28.34 x 28.34	mm
Pixel Pitch (W x H)	0.1155 x 0.1155	mm
Resolution	240 (RGB) x 240	/
Brightness	500	cd/m <sup>2</sup>
LCD Interface Type	SPI	/
Color Depth	262K	/
Pixel Arrangement	RGB Vertical Stripe	/
With/Without Touch	With Projected Capacitive Touch Panel	/
CTP Driver	ILI2130	/
Touch Interface Type	I2C	/
Bonding Technology	Optical Bonding	/
Weight	10	g

**Note 1.** RoHS3 compliant

**Note 2.** LCM weight tolerance:  $\pm 5\%$ .

## 1. REVISION RECORD

REV NO.	REV DATE	CONTENTS	REMARKS
1.0	2024-11-26	Initial Release	

## 2. CONTENTS

1.	REVISION RECORD .....	3
2.	CONTENTS .....	4
3.	MODULE CLASSIFICATION INFORMATION .....	5
4.	MODULE DRAWING .....	6
5.	ABSOLUTE MAXIMUM RATINGS .....	7
6.	ELECTRICAL CHARACTERISTICS .....	7
7.	BACKLIGHT ELECTRICAL CHARACTERISTICS .....	8
8.	ELECTRO-OPTICAL CHARACTERISTICS .....	9
9.	INTERFACES DESCRIPTION .....	12
9.1	TFT assignment .....	12
10.	TIMING CHARACTERISTICS .....	14
11.	INSPECTION .....	16
11.1	Inspection condition .....	17
11.2	Inspection standard .....	18
12.	RELIABILITY TEST .....	20
13.	LEGAL INFORMATION .....	21
14.	CONTACT .....	22

### 3. MODULE CLASSIFICATION INFORMATION

RV	T	15	M	D	P	N	W	C	00	B
1.	2.	3.	4.	5.	6.	7.	8.	9.	10.	11.

NO.	PARAMETER	SYMBOL
1.	BRAND	RV - Riverdi
2.	PRODUCT TYPE	T - TFT Standard
3.	DISPLAY SIZE	15 - 1.54"
4.	MODEL SERIAL NO.	M - Standard Brightness, IPS
5.	RESOLUTION	D - 240 x 240 px
6.	INTERFACE	T - SPI
7.	FRAME	N - Without Mounting Metal Frame
8.	BACKLIGHT TYPE	W - LED White
9.	TOUCH PANEL	C - With Projected Capacitive Touch Panel
10.	VERSION	00 - (00-99)
11.	BONDING TECHNOLOGY	B - Optical Bonding

Revision:	Changes:	Date:
1.0	Initial Case	2024.11.26

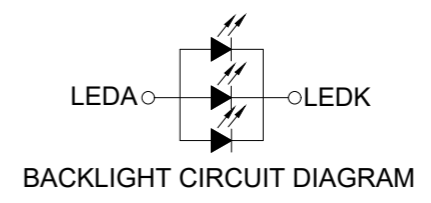
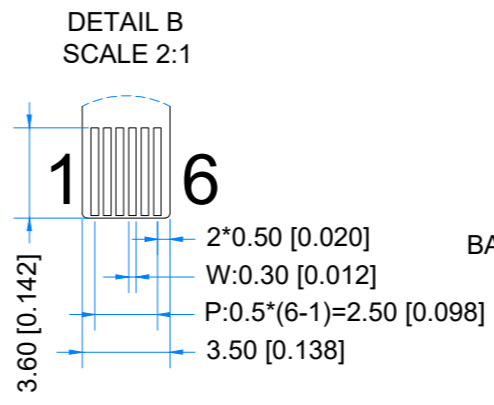
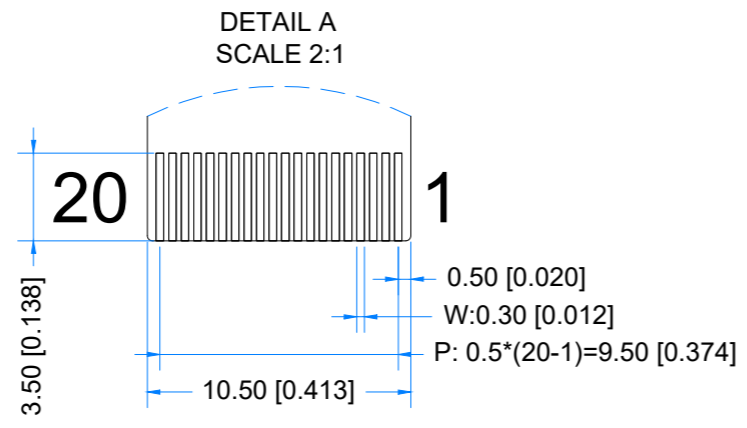
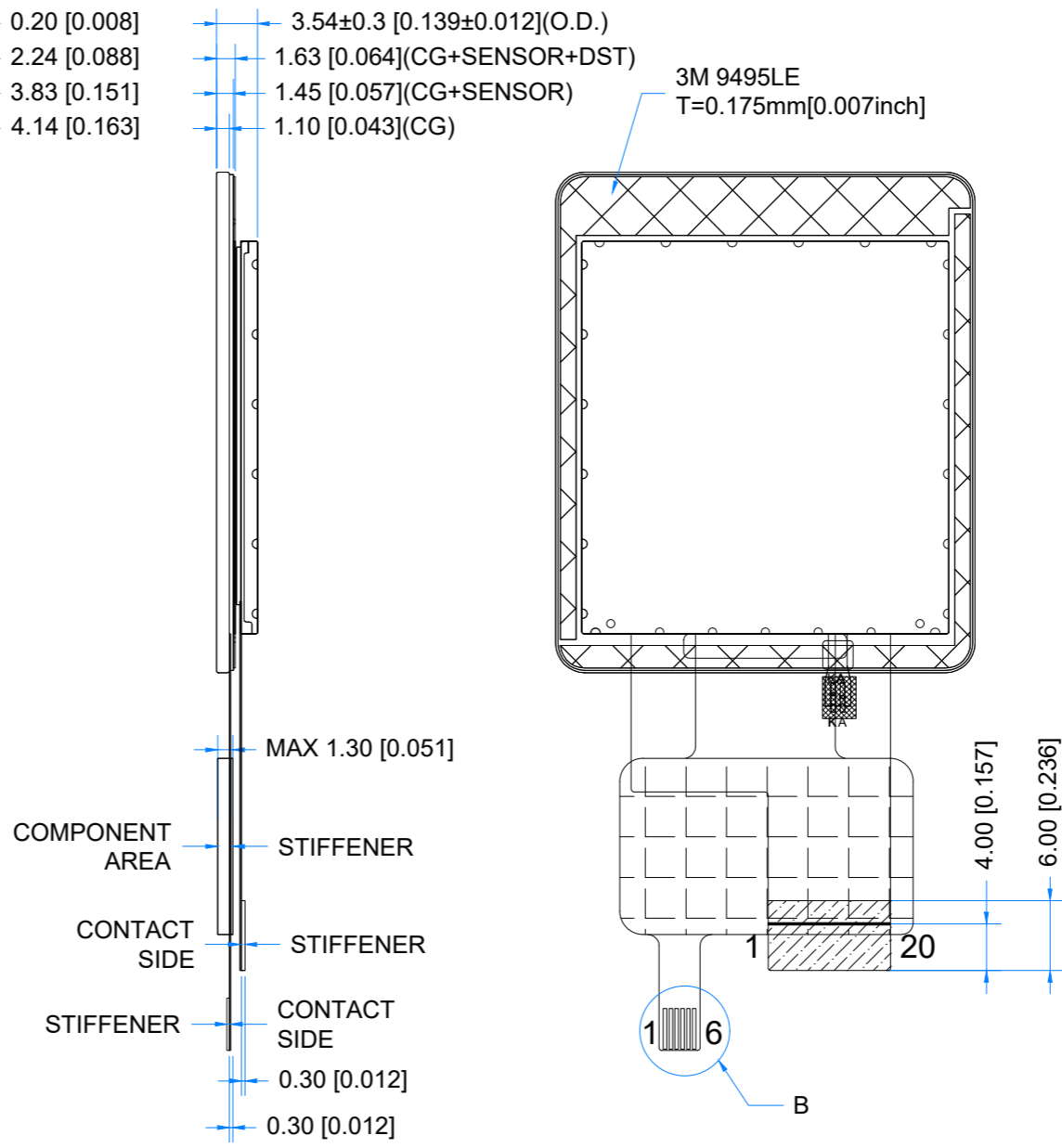
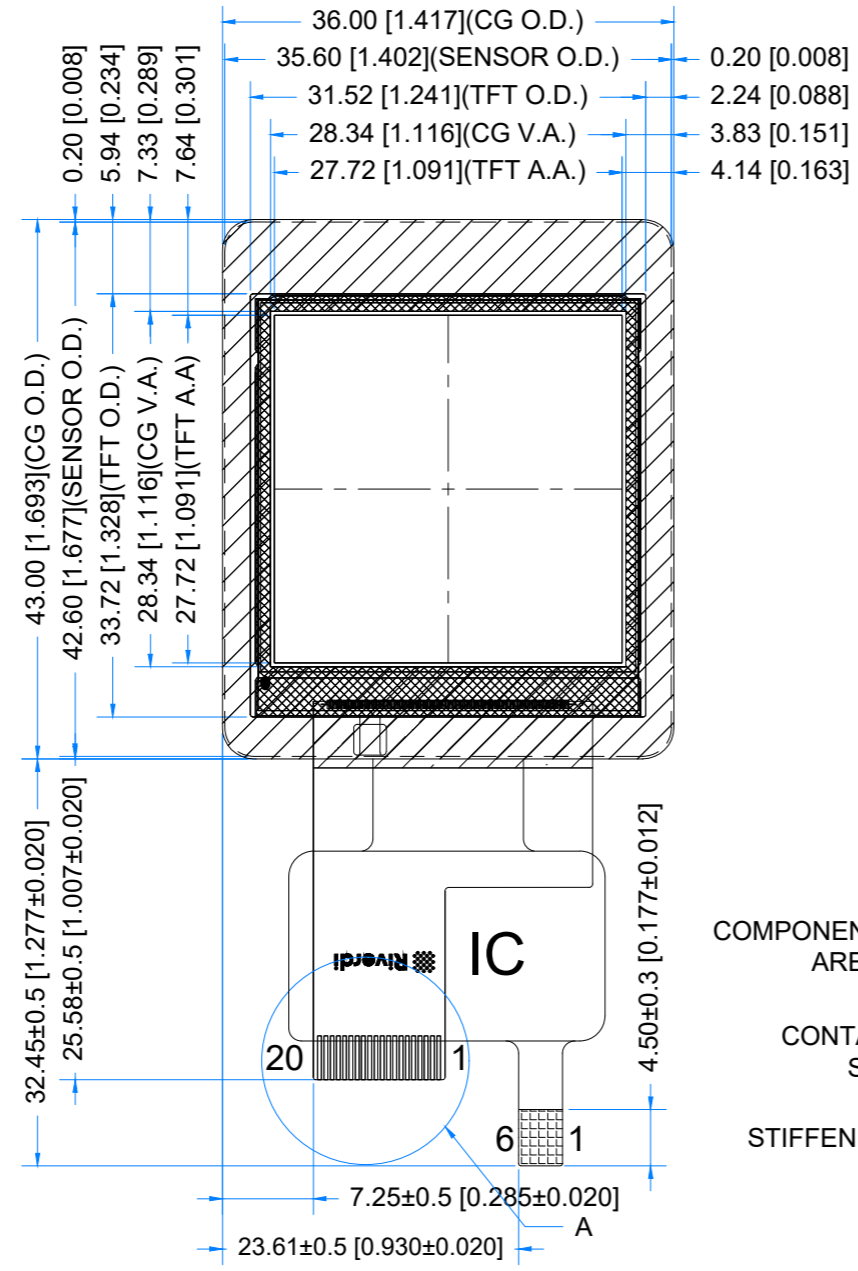

PINOUT ON THE 2ND PAGE

**TFT NOTES:**  
1. DISPLAY TYPE: TFT, TRANSMISSIVE, NORMALLY BLACK  
2. RESOLUTION: 240\*240  
3. VIEWING ANGLE: FREE  
4. DRIVER IC: ST7789P3  
5. OPERATING VOLTAGE:  $V_{DD}=2.8V$   
6. SURFACE LUMINANCE:  $500cd/m^2$   
7. BACKLIGHT: 3LEDS,  $V_f=3.2V$ ,  $I_f=60mA$

**TP NOTES:**  
1. TP STRUCTURE: G+G  
2. DRIVER IC: ILI2130  
3. SURFACE HARDNESS:  $\geq 6H$   
4. TRANSMITTANCE:  $>85\%$

**GENERAL NOTES:**  
1. OPERATING TEMPERATURE:  $-20^{\circ}C \sim 70^{\circ}C$   
2. STORAGE TEMPERATURE:  $-30^{\circ}C \sim 80^{\circ}C$   
3. WITHOUT INDIVIDUAL TOLERANCE:  $\pm 0.2mm$   
4. RoHS COMPLIANT

PN: RVT15MDTNWC00-B		2024.11.26	1:0.60	
SN:				
DRAWN: M.Natywa		2024.11.26	[mm]	
CHECKED: M.Wierzbowski		2024.11.26		
APPR:			ISO A3	P. 1 of 1

## 5. ABSOLUTE MAXIMUM RATINGS

PARAMETER	SYMBOL	MIN	TYP	MAX	UNIT
Supply Voltage (logic)	IOVCC	-0.3	-	4.6	V
Interface Supply Voltage	VCC2.8	-0.3	-	4.6	V
Input Voltage	V <sub>in</sub>	-0.3	-	VDD+0.3	V

**Note.** The above are maximum values. If exceeded, they may cause permanent damage to the unit.

## 6. ELECTRICAL CHARACTERISTICS

PARAMETER	SYMBOL	MIN	TYP	MAX	UNIT
Interface Operation Voltage	IOVCC	1.7	1.8	3.3	V
Interface Supply Voltage	VCC	2.5	2.8	3.3	V
Input High Voltage for LCD	V <sub>IH</sub>	0.7*IOVCC	-	IOVCC	V
Input Low Voltage for LCD	V <sub>IL</sub>	VSS	-	0.3*IOVCC	V
Output High Voltage for LCD	V <sub>OH</sub>	0.8*IOVCC	-	IOVCC	V
Output Low Voltage for LCD	V <sub>OL</sub>	VSS	-	0.3*IOVCC	V

## 7. BACKLIGHT ELECTRICAL CHARACTERISTICS

PARAMETER	SYMBOL	MIN	TYP	MAX	UNIT	NOTE
Backlight Driving Voltage	$V_F$	-	3.2	-	V	Notes 1, 2
Backlight Driving Current	$I_F$	-	60	-	mA	
Backlight Power Consumption	$W_{BL}$	-	0.192	-	W	
Backlight Lifetime	-	-	30,000	-	hours	Note 3

**Note 1.** Unless specified, the ambient temperature  $T_a = 25^\circ\text{C}$

**Note 2.** The recommended operating conditions refer to a range in which operation of this product is guaranteed. The operation cannot be guaranteed if the absolute maximum values exceed.

**Note 3.** If LED is driven by high current, high ambient temperature and humidity condition, the lifetime of LED will be reduced. Operating life means brightness goes down to 50% initial brightness. Typical operating lifetime is estimated data.

## 8. ELECTRO-OPTICAL CHARACTERISTICS

ITEM	SYMBOL	CONDITION	MIN	TYP	MAX	UNIT	RMK	NOTE
Response Time	Tr+Tf	$\theta=0^\circ$ $\phi=0^\circ$ Ta=25 °C	-	30	-	ms	FIG 1.	4, 7
Contrast Ratio	Cr		-	900	-	---	FIG 2.	1, 7
Surface Luminance	Lv		-	500	-	cd/m <sup>2</sup>		2, 7
Viewing Angle Range	$\theta$	$\phi = 90^\circ$	-	80	-	deg	FIG 3.	6
		$\phi = 270^\circ$	-	80	-	deg		
		$\phi = 0^\circ$	-	80	-	deg		
		$\phi = 180^\circ$	-	80	-	deg		
CIE (x, y) Chromaticity	Rx	$\theta=0^\circ$ $\phi=0^\circ$ Ta=25 °C	-	0.608	-	-	FIG 2.	5,7
	Ry		-	0.323	-	-		
	Gx		-	0.317	-	-		
	Gy		-	0.549	-	-		
	Bx		-	0.145	-	-		
	By		-	0.138	-	-		
	Wx		-	0.286	-	-		
	Wy		-	0.323	-	-		

**Note 1.** Contrast Ratio (CR) is defined mathematically as below, for more information see Figure 2.

$$\text{Contrast Ratio} = \frac{\text{Average Surface Luminance with all white pixels (P1, P2, P3, P4, P5)}}{\text{Average Surface Luminance with all black pixels (P1, P2, P3, P4, P5)}}$$

**Note 2.** Surface luminance is the LCD surface from the surface with all pixels displaying white. For more information see Figure 2.

$$L_v = \text{Average Surface Luminance with all white pixels (P1, P2, P3, P4, P5)}$$

**Note 3.** The uniformity in surface luminance  $\delta$  WHITE is determined by measuring luminance at each test position 1 through 5, and then dividing the minimum luminance of 5 points luminance by maximum luminance of 5 points luminance. For more information see Figure 2.

$$\delta \text{ WHITE} = \frac{\text{Minimum Surface Luminance with all white pixels (P1, P2, P3, P4, P5)}}{\text{Maximum Surface Luminance with all white pixels (P1, P2, P3, P4, P5)}}$$

**Note 4.** Response time is the time required for the display to transition from white to black (Rise Time, Tr) and from black to white (Decay Time, Tf). For additional information see Figure 1. The test equipment is BM-7A.

**Note 5.** CIE (x, y) chromaticity, the x, y value is determined by measuring luminance at each test position 1 through 5, and then make average value.

**Note 6.** For TFT module, viewing angle is the angle at which the contrast ratio is greater 10. The angles are determined for the horizontal or x axis and the vertical or y axis with respect to the z axis which is normal to LCD surface. For more information see Figure 3.

**Note 7.** Viewing angle is measured at the center point of the LCD by CONOSCOPE (ergo-80). For response time testing, the testing data is based on BM-7A. Instruments for Contrast Ratio, Surface Luminance, Luminance Uniformity, Chromaticity the test data is based on SR-3A.

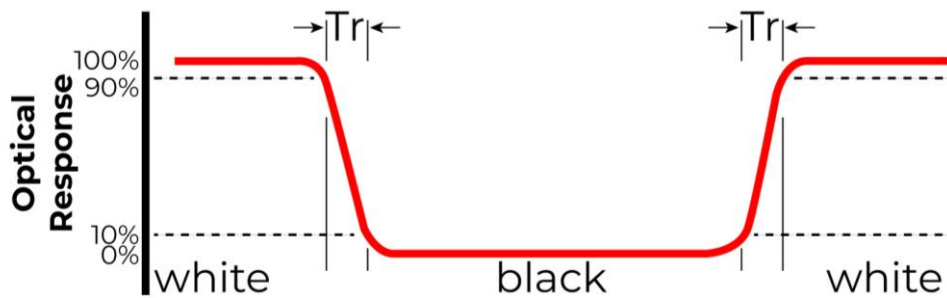

Figure 1. The definition of response time

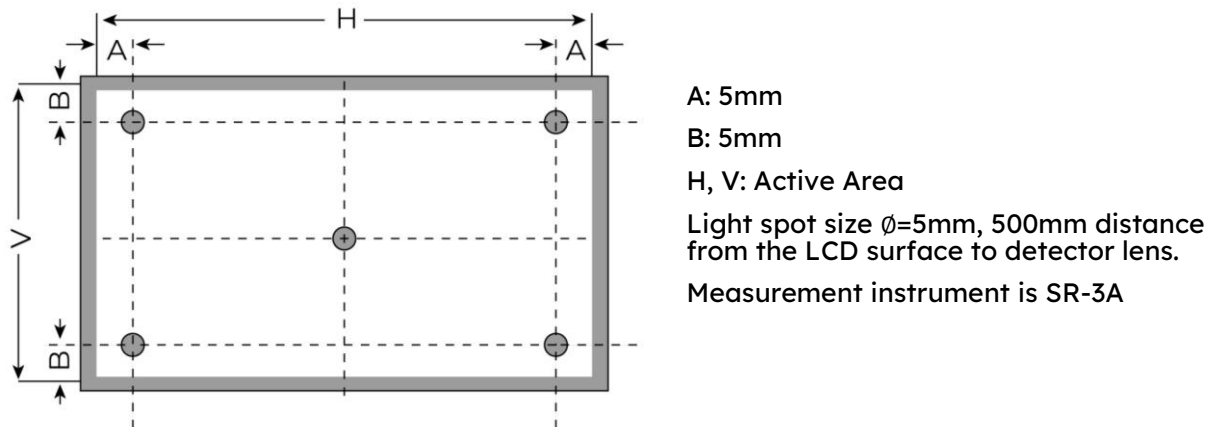

Figure 2. Measuring method for Contrast ratio, surface luminance, Luminance uniformity, CIE (x, y) chromaticity

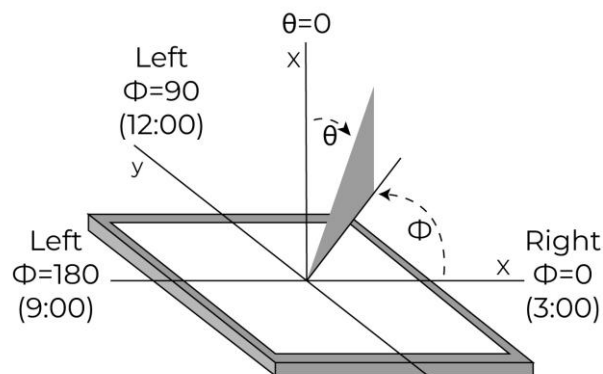

Figure 3. The definition of viewing angle

## 9. INTERFACES DESCRIPTION

### 9.1 TFT assignment

PIN	SYMBOL	I/O/P	DESCRIPTION
1	LEDK	P	LED-
2	LEDK	P	LED-
3	GND	P	Ground
4	GND	P	Ground
5	FRAME	-	Tearing effect signal (used to sync MCU to frame memory)
6	SDA	I/O	Serial data input/output
7	RS(WRX)	I	Display data/command selection pin
8	SCL	I	Clock signal
9	CS	I	Chip select
10	RESET	I	Reset signal
11	IOVCC	P	Power supply for I/O
12	IOVCC	P	Power supply for I/O
13	VCC	P	Power supply for Digital, Analog
14	VCC	P	Power supply for Digital, Analog
15	GND	P	Ground
16	GND	P	Ground
17	NC	-	Not connected
18	NC	-	Not connected
19	LEDA	P	LED+
20	LEDA	P	LED+

**Note 1.** I: Input, O: Output, P: Power

## 9.2 CTP assingment

PIN	SYMBOL	I/O/P	DESCRIPTION
<b>1</b>	RST	I	Reset signal
<b>2</b>	INT	O	Interupt output signal
<b>3</b>	SDA	I/O	I <sup>2</sup> C serial data
<b>4</b>	SCL	I/O	I <sup>2</sup> C serial clock
<b>5</b>	GND	P	Ground
<b>6</b>	VDD	P	Power supply

## 10. TIMING CHARACTERISTICS

SIGNAL	SYMBOL	PARAMETER	MIN	MAX	UNIT	DESCRIPTION
CSX	T <sub>CSS</sub>	Chip select setup time (write)	15	-	ns	
	T <sub>CSh</sub>	Chip select hold time (write)	15	-	ns	
	T <sub>CSS</sub>	Chip select setup time (read)	60	-	ns	
	T <sub>SCC</sub>	Chip select hold time (read)	65	-	ns	
	T <sub>CHW</sub>	Chip select „H” pulse width	40	-	ns	
SCL	T <sub>SCYCW</sub>	Serial clock cycle (write)	16	-	ns	write command & data ram
	T <sub>SHW</sub>	SCL „H” pulse width (write)	7	-	ns	
	T <sub>SLW</sub>	SCL „L” pulse width (write)	7	-	ns	
	T <sub>SCYCR</sub>	Serial clock cycle (read)	150	-	ns	read command & data ram
	T <sub>SHR</sub>	SCL „H” pulse width (read)	60	-	ns	
	T <sub>SLR</sub>	SCL „L” pulse width (read)	60	-	ns	
D/CX	T <sub>DCS</sub>	D/CX setup time	10	-	ns	
	T <sub>DCH</sub>	D/CX hold time	10	-	ns	
SDA (DIN)	T <sub>SDS</sub>	Data setup time	7	-	ns	
	T <sub>SDH</sub>	Data hold time	7	-	ns	
DOUT	T <sub>ACC</sub>	Access time	10	50	ns	For maximum CL = 30 pF For minimum CL = 8 pF
	T <sub>OH</sub>	Output disable time	15	50	ns	

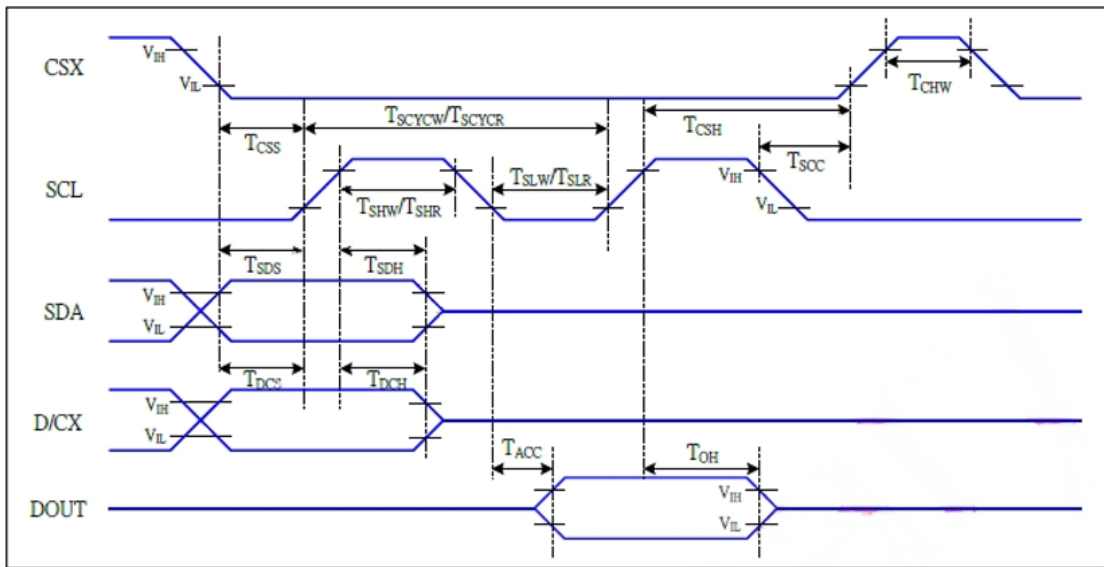

Figure 3. 4-line serial interface timing characteristics

## 11. CAPACITIVE TOUCH SCREEN PANEL SPECIFICATIONS

### 11.1 Mechanical characteristics

DESCRIPTION	SPECIFICATION	REMARK
<b>Touch Panel Size</b>	1.54 inch	
<b>Outline Dimension of CTP</b>	43.00 mm x 36.00 mm	
<b>Product Thickness</b>	3.54 mm	
<b>Glass Thickness</b>	1.1mm	
<b>CTP View Area</b>	28.34 mm x 28.34 mm	
<b>Sensor Active Area</b>	27.72 mm x 27.72 mm	
<b>Surface Hardness</b>	6H	

### 11.2 Electrical characteristics

DESCRIPTION	SPECIFICATION	REMARK
<b>Linearity</b>	+/-1.5mm	
<b>Controller</b>	ILI2130	
<b>Resolution</b>	240 x 240	
<b>Device address 7-bit</b>	0x41	

## 12. INSPECTION

Standard acceptance/rejection criteria for TFT module

### 12.1 Inspection condition

Ambient conditions:

- Temperature:  $25 \pm 2^\circ\text{C}$
- Humidity:  $(60 \pm 10) \%RH$
- Illumination: Single fluorescent lamp non-directive (300 to 700 lux)

Viewing distance:  $35 \pm 5\text{cm}$  between inspector bare eye and LCD.

Viewing Angle: U/D:  $45^\circ/45^\circ$ , L/R:  $45^\circ/45^\circ$

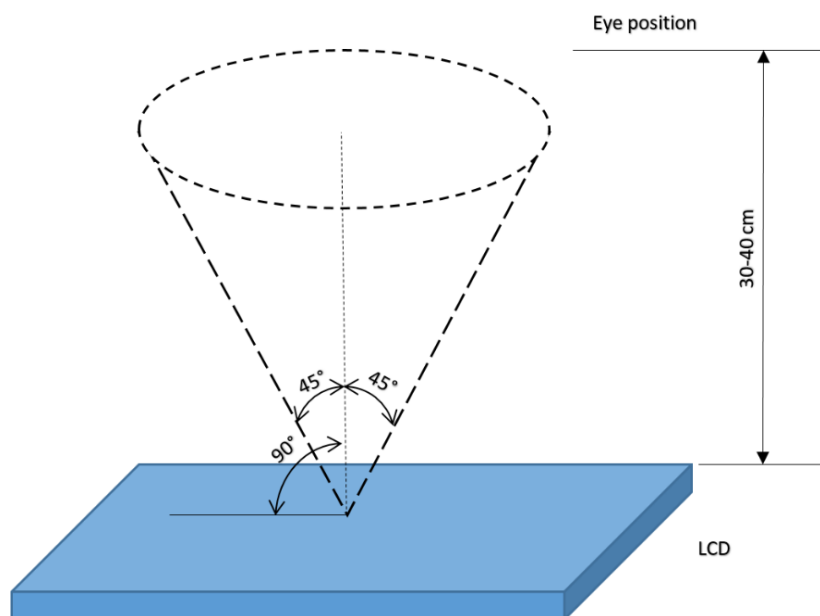

## 12.2 Inspection standard

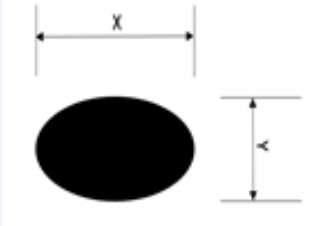
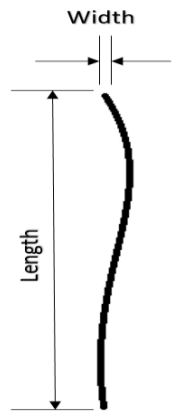
ITEM	CRITERION															
Black spots, white spots, light leakage, Foreign Particle (round Type)	<div style="text-align: center;">  </div> <p style="text-align: center;"><math>D=(x+y)/2</math></p> <p style="text-align: center;">Spots density: 10 mm</p> <table border="1" style="width: 100%; margin-top: 10px;"> <thead> <tr> <th colspan="2" style="text-align: center;">Size = 1.54"</th> </tr> <tr> <th style="width: 50%;">Average Diameter</th> <th style="width: 50%;">Qualified Qty</th> </tr> </thead> <tbody> <tr> <td><math>D \leq 0.2 \text{ mm}</math></td> <td>Ignored</td> </tr> <tr> <td><math>0.2 \text{ mm} &lt; D \leq 0.3 \text{ mm}</math></td> <td><math>N \leq 5</math></td> </tr> <tr> <td><math>0.5 \text{ mm} &lt; D</math></td> <td>Not allowed</td> </tr> </tbody> </table>	Size = 1.54"		Average Diameter	Qualified Qty	$D \leq 0.2 \text{ mm}$	Ignored	$0.2 \text{ mm} < D \leq 0.3 \text{ mm}$	$N \leq 5$	$0.5 \text{ mm} < D$	Not allowed					
	Size = 1.54"															
	Average Diameter	Qualified Qty														
	$D \leq 0.2 \text{ mm}$	Ignored														
	$0.2 \text{ mm} < D \leq 0.3 \text{ mm}$	$N \leq 5$														
$0.5 \text{ mm} < D$	Not allowed															
LCD black spots, white spots, light leakage (line Type)	<div style="text-align: center;">  </div> <p style="text-align: center;">Spots density: 10 mm</p> <table border="1" style="width: 100%; margin-top: 10px;"> <thead> <tr> <th colspan="3" style="text-align: center;">Size = 1.54"</th> </tr> <tr> <th style="width: 33%;">Length</th> <th style="width: 33%;">Width</th> <th style="width: 33%;">Qualified Qty</th> </tr> </thead> <tbody> <tr> <td style="text-align: center;">-</td> <td style="text-align: center;"><math>W \leq 0.05</math></td> <td>Ignored</td> </tr> <tr> <td style="text-align: center;"><math>L \leq 3.0</math></td> <td style="text-align: center;"><math>0.05 &lt; W \leq 0.1</math></td> <td style="text-align: center;"><math>N \leq 3</math></td> </tr> <tr> <td style="text-align: center;"><math>5.0 &lt; L</math></td> <td style="text-align: center;"><math>0.1 &lt; W</math> <math>5.0 &lt; L</math></td> <td style="text-align: center;">Not allowed</td> </tr> </tbody> </table>	Size = 1.54"			Length	Width	Qualified Qty	-	$W \leq 0.05$	Ignored	$L \leq 3.0$	$0.05 < W \leq 0.1$	$N \leq 3$	$5.0 < L$	$0.1 < W$ $5.0 < L$	Not allowed
	Size = 1.54"															
	Length	Width	Qualified Qty													
	-	$W \leq 0.05$	Ignored													
$L \leq 3.0$	$0.05 < W \leq 0.1$	$N \leq 3$														
$5.0 < L$	$0.1 < W$ $5.0 < L$	Not allowed														
Bright/Dark Dots	<table border="1" style="width: 100%; margin-top: 10px;"> <thead> <tr> <th colspan="2" style="text-align: center;">Size = 1.54"</th> </tr> <tr> <th style="width: 50%;">Item</th> <th style="width: 50%;">Qualified Qty</th> </tr> </thead> <tbody> <tr> <td style="text-align: center;">Bright dots</td> <td style="text-align: center;">0</td> </tr> <tr> <td style="text-align: center;">Dark dots</td> <td style="text-align: center;">0</td> </tr> <tr> <td style="text-align: center;">Cluster Bright Dots and Dark Dots</td> <td style="text-align: center;">0</td> </tr> <tr> <td style="text-align: center;">Total Bright and Dark Dots</td> <td style="text-align: center;">0</td> </tr> </tbody> </table>	Size = 1.54"		Item	Qualified Qty	Bright dots	0	Dark dots	0	Cluster Bright Dots and Dark Dots	0	Total Bright and Dark Dots	0			
	Size = 1.54"															
	Item	Qualified Qty														
	Bright dots	0														
	Dark dots	0														
Cluster Bright Dots and Dark Dots	0															
Total Bright and Dark Dots	0															

Clear spots	Size = 1.54"		
	Average Diameter		Qualified Qty
	D < 0.2 mm		Ignored
	0.2 mm < D < 0.3 mm		4
	0.3 mm < D < 0.5 mm		2
	0.5 mm < D		0
	Spots density: 10 mm		
Touch panel spots	Size = 1.54"		
	Average Diameter		Qualified Qty
	D < 0.3 mm		Ignored
	0.3 mm < D < 0.5 mm		N ≤ 5
	0.5 mm < D		0
Touch panel white line scratch	Size ≤ 5.0"		
	Length	Width	Qualified Qty
	-	W ≤ 0.07	Ignored
	L ≤ 5.0	0.07 < W < 0.05	N ≤ 5
	-	0.05 < W	0

## 13. RELIABILITY TEST

NO.	TEST ITEM	TEST CONDITION	NOTE
1	High Temperature Storage	80°C/96 hours	Note 1
2	Low Temperature Storage	-30°C/96 hours	
3	High Temperature Operating	70°C/96 hours	
4	Low Temperature Operating	-20°C/96 hours	
5	High Temperature and High Humidity	Humidity 60°C, 90%RH, 96Hrs	
6	Electro static discharge	Contact = ±4kV, Air = ±8kV,	Note 2
7	Thermal Cycling Test (No operation)	-20°C -> 25°C -> 70°C -> 25°C 30 min; 5 min; 30 min; 5 min 10 cycles	
8	Vibration Test	Frequency: 10 ÷ 50 Hz. Swing: 0.75mm Time: 30 min	
9	Fall test (endurance test dropping the LCM from a high place)	Height: 600 mm	

**Note 1.** Sample quantity for each test item is 5 ÷ 10 pcs.

**Note 2.** The device is kept at room temperature for 2 hours prior to starting the test

## 14. LEGAL INFORMATION

CE marking is usually obligatory only for a complete end product. Riverdi display modules are semi-finished goods which are used as inputs to become part of the finished products.

Therefore, Riverdi display modules are not CE marked.

This is not a standalone product. It was designed as an electronic component. It needs integration with a whole system to be fully functional.

Riverdi grants the guarantee for the proper operation of the goods for a period of 12 months from the date of possession of the goods. If in a consequence of this guaranteed execution the customer has received the defects-free item as replacement for the defective item, the effectiveness period of this guarantee shall start anew from the moment the customer receives the defects-free item.

Information about device is the property of Riverdi and may be the subject of patents pending or granted. It is not allowed to copy or disclosed this document without prior written permission.

Riverdi endeavors to ensure that all contained information in this document is correct but does not accept liability for any error or omission. Riverdi products are in developing process and published information may be not up to date. Riverdi reserves the right to update and makes changes to Specifications or written material without prior notice at any time. It is important to check the current position with Riverdi.

Images and graphics used in this document are only for illustrative the purpose. All images and graphics are possible to be displayed on the range products of Riverdi, however the quality may vary. Riverdi is no liable to the buyer or to any third party for any indirect, incidental, special, consequential, punitive, or exemplary damages (including without limitation lost profits, lost savings, or loss of business opportunity) relating to any product, service provided or to be provided by Riverdi, or the use or inability to use the same, even if Riverdi has been advised of the possibility of such damages.

Riverdi products are not fault tolerant nor designed, manufactured or intended for use or resale as on line control equipment in hazardous environments requiring fail-safe performance, such as in the operation of nuclear facilities, aircraft navigation or communication systems, air traffic control, direct life support machines or weapons systems in which the failure of the product could lead directly to death, personal injury or severe physical or environmental damage ('High-Risk Activities'). Riverdi and its suppliers specifically disclaim any expressed or implied warranty of fitness for High-Risk Activities. Using Riverdi products and devices in 'High-Risk Activities' and in any other application is entirely at the buyer's risk, and the buyer agrees to defend, indemnify and hold harmless Riverdi from all damages, claims or expenses resulting from such use. No licenses are conveyed, implicitly or otherwise, under any Riverdi intellectual property rights.

## 15. CONTACT

### Your Success is Our Priority

Stuck on a technical challenge? Need expert guidance?  
Our dedicated support team is just a message away.

Contact us at

[contact@riverdi.com](mailto:contact@riverdi.com)

We're here to ensure your project's success, every step of the way!